

TLV320AIC22C

DUAL VOICE OVER INTERNET PROTOCOL (VoIP) CODEC

SPAS041B – OCTOBER 2001 – REVISED JANUARY 2003

- Two 16-Bit Analog-to-Digital Converters (ADCs)
- Two 16-Bit Digital-to-Analog Converters (DACs)
- Programmable Input/Output Gain
- Analog Crosspoint to Connect the Two Coders/Decoders (Codecs) to Any of the I/O Ports – Controlled Through the Serial Port or the Inter-Integrated Circuit (I²C) Bus
- 8-Bit A-Law/ μ -Law Companded Data or 16-Bit Linear Data Complying With G.711 Standard
- Filters Comply With G.712 and G.722 Standards
- Programmable Analog-to-Digital and Digital-to-Analog Conversion Rate
- Typical 77-dB Signal-to-Noise + Distortion for ADC
- Typical 78-dB Signal-to-Noise + Distortion for DAC
- Supports 8- and 16-kHz Sampling Rates
- Preamplifiers for Microphone, Handset, Headset, and Speakerphone Gain Selectable Via the Serial Port or I²C Bus
- 2.5-V Microphone Bias Voltage
- Seamless Interface to a Single Multichannel Buffered Serial Port (McBSP) of a C54x™ or a C6x Digital Signal Processor (DSP)
- Four TLV320AIC22C ICs Can Be Cascaded Together to Allow up to Eight Channels
- 2s-Complement Data Format
- Differential Outputs
- Typical Low Crosstalk < -85 dB
- Hardware/Software Power Down
- Independent Power Down for Drivers
- Single 3.3-V Supply Operation
- 120-mW Typical Power Consumption
- Available in 48-Terminal Low-Profile Plastic Quad Flatpack (LQFP) Package

description

The TLV320AIC22C contains two coders/decoders (codecs) for voice applications, including voice over internet protocol (VoIP). It features two analog-to-digital converter (ADC) channels and two digital-to-analog converter (DAC) channels that can be connected to a handset, headset, speaker, microphone, or a subscriber line via an analog crosspoint.

The TLV320AIC22C has a flexible serial interface that allows the two channels of the TLV320AIC22C to be interfaced to a single multichannel buffered serial port (McBSP) of the external digital signal processor (DSP). The two channels share the digital interface at different time slots. Up to four TLV320AIC22C units can be cascaded together to obtain eight channels. For control purposes, either the serial interface or the inter-integrated circuit (I²C) interface can be used. Programmable-gain amplifiers (PGAs), preamp gain, microphone bias voltages, and analog crosspoint are programmed through the serial interface or the I²C interface. The TLV320AIC22C can be powered down, via a dedicated terminal or by using software control, to reduce power dissipation.

The TLV320AIC22C is available in a 48-terminal LQFP package and is characterized for operation from -40°C to 85°C.

ORDERING INFORMATION

T_A	PACKAGE
	PLASTIC QUAD FLATPACK (PT)
-40°C to 85°C	TLV320AIC22CPT



Please be aware that an important notice concerning availability, standard warranty, and use in critical applications of Texas Instruments semiconductor products and disclaimers thereto appears at the end of this data sheet.

C54x and TMS320C54x are trademarks of Texas Instruments Incorporated.

PRODUCTION DATA information is current as of publication date. Products conform to specifications per the terms of Texas Instruments standard warranty. Production processing does not necessarily include testing of all parameters.



POST OFFICE BOX 655303 • DALLAS, TEXAS 75265

Copyright © 2003, Texas Instruments Incorporated

TLV320AIC22C

DUAL VOICE OVER INTERNET PROTOCOL (VoIP) CODEC

SPAS041B – OCTOBER 2001 – REVISED JANUARY 2003

PT PACKAGE
(TOP VIEW)

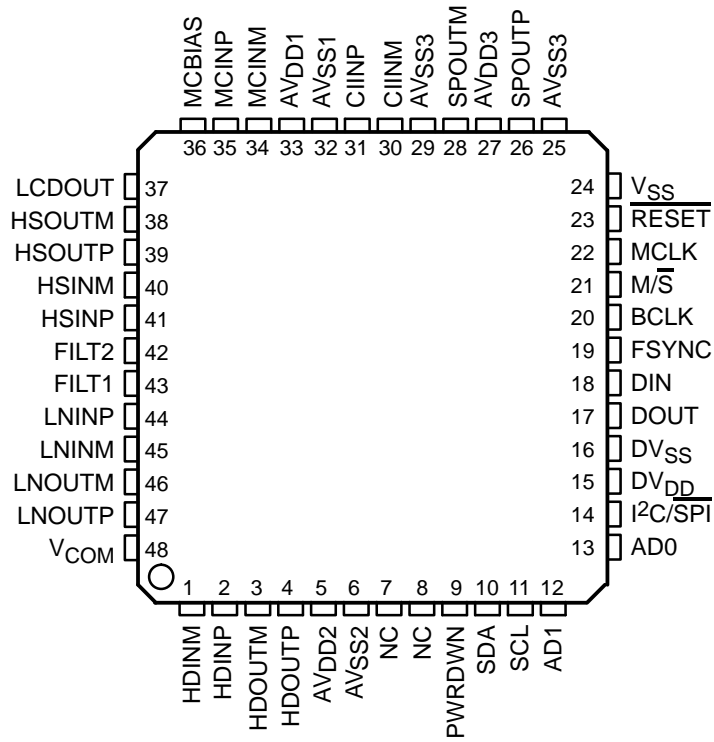

NC – No internal connection

TLV320AIC22C DUAL VOICE OVER INTERNET PROTOCOL (VoIP) CODEC

SPAS041B – OCTOBER 2001 – REVISED JANUARY 2003

functional block diagram

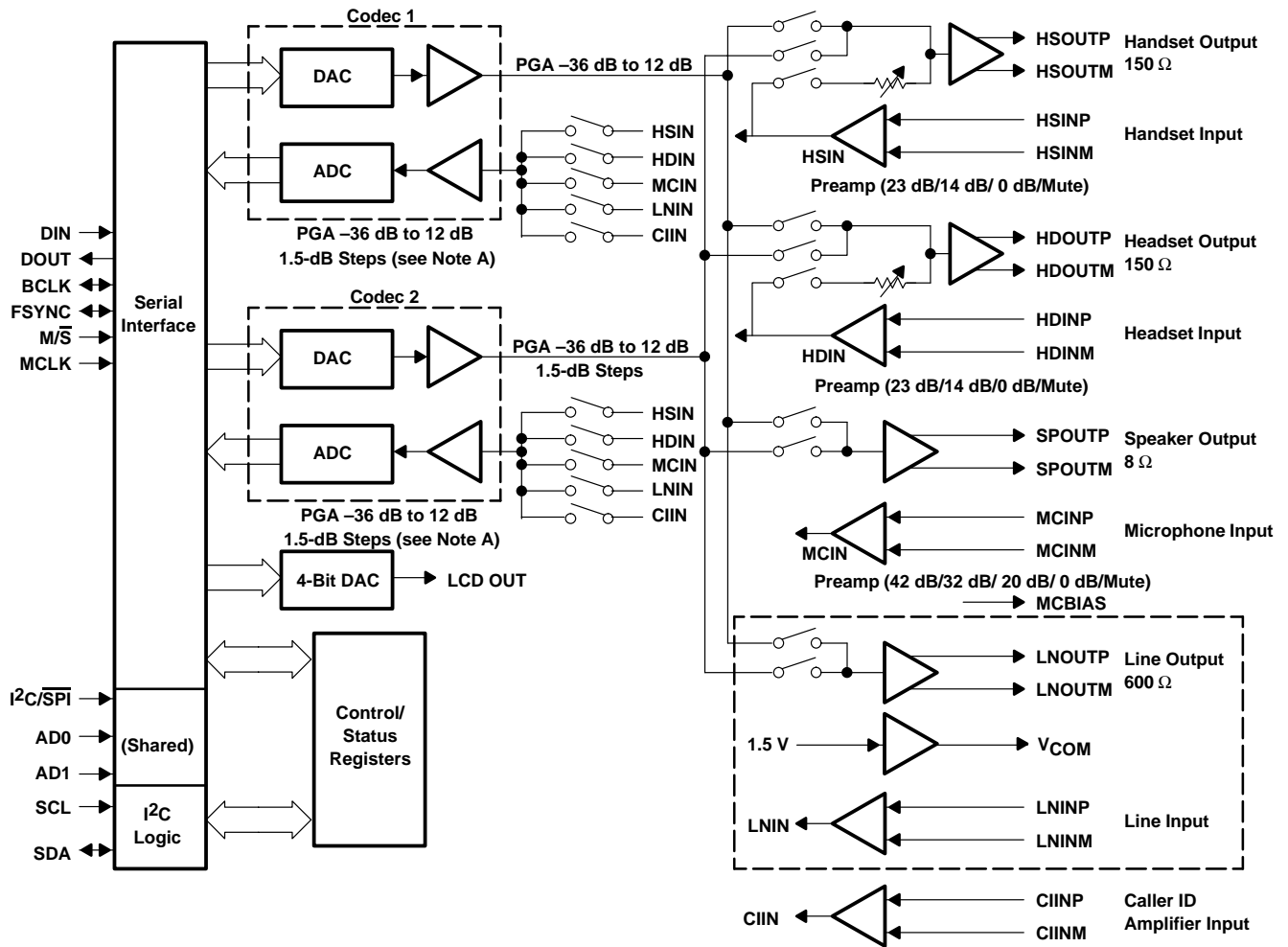

- NOTES: A. The attenuation on the ADC PGA (0 dB to -36 dB) is done after the analog-to-digital conversion. This attenuation cannot prevent clipping. To prevent clipping, both the preamp gain and the PGA should be lowered to the required value.
 B. Input and output analog signals are differential. All switches are register controlled.

functional block diagram (one of two codecs shown)

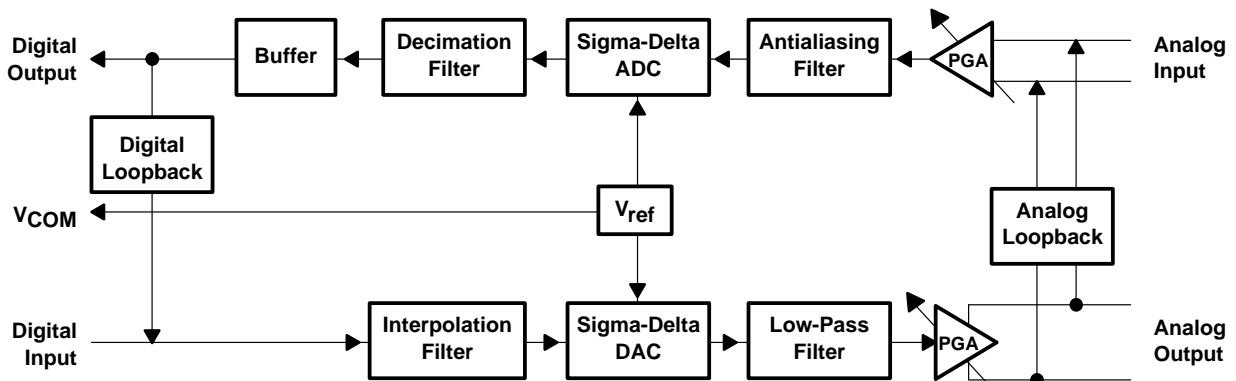

TLV320AIC22C

DUAL VOICE OVER INTERNET PROTOCOL (VoIP) CODEC

SPAS041B – OCTOBER 2001 – REVISED JANUARY 2003

Terminal Functions

TERMINAL NAME	NO.	I/O	DESCRIPTION
AD1	12	I	Address. In I ² C mode, AD1 is used with AD0 to form the lower two bits of the 7-bit I ² C chip address. The upper five bits are fixed at 11100. AD1 is used in conjunction with AD0 to assign the two time slots for the codec in serial-port mode. AD1 is the MSB.
AD0	13	I	Address. In I ² C mode, AD0 is used with AD1 to form the lower two bits of the 7-bit I ² C chip address. The upper five bits are fixed at 11100. AD0 is used in conjunction with AD1 to assign the two time slots for the codec in serial-port mode. AD0 is the LSB.
AV _{DD1}	33	I	Analog power supply. Connect to AV _{DD2} (see Note 1).
AV _{DD2}	5	I	Analog power supply. Connect to AV _{DD1} (see Note 1).
AV _{DD3}	27	I	Analog power supply for 8-Ω speaker driver. AV _{DD3} can be connected to AV _{DD1} and AV _{DD2} . Because this signal requires large amounts of current, it is recommended that a separate PCB trace be run to this terminal and connected to the main supply at the power-supply connection to the PC board (see Note 1).
AV _{SS1}	32	I	Analog ground. Connect to AV _{SS2} (see Note 1).
AV _{SS2}	6	I	Analog ground. Connect to AV _{SS1} (see Note 1).
AV _{SS3}	25 29	I	Analog ground for 8-Ω speaker driver. AV _{SS3} can be connected to AV _{SS1} and AV _{SS2} . Because this signal requires large amounts of current, it is recommended that a separate PCB trace be run to this terminal and connected to the main supply at the power-supply connection to the PC board (see Note 1).
BCLK	20	I/O	Bit clock. BCLK clocks serial data into DIN and out of DOUT. When configured as an output (master mode), BCLK is generated internally by multiplying the frame-synchronization signal frequency by 256. When configured as an input (slave mode), BCLK is an input and must be synchronous with the master clock and frame synchronization.
CIINM	30	I	Caller ID amplifier analog inverting input
CIINP	31	I	Caller ID amplifier analog noninverting input
DIN	18	I	Data input. DIN receives the DAC input data and register data from the external DSP or controller and is synchronized to BCLK. Data is latched on the falling edge of BCLK in the two time slots that are specified by the AD1 and AD0 bits. Codec 1 receives data in the first assigned time slot, followed by codec 2 receiving data in the second assigned time slot.
DOUT	17	O	Data output. DOUT transmits the ADC output bits and the register data. It is synchronized to BCLK. Data is transmitted on the rising edge of BCLK in the two time slots that are specified by the AD1 and AD0 bits. DOUT is at high impedance during time slots not assigned to the codec. Codec 1 transmits data in the first assigned time slot, followed by codec 2 in the second assigned time slot.
DV _{DD}	15	I	Digital power supply (see Note 1)
DV _{SS}	16	I	Digital ground (see Note 1)
FILT1	43	O	Reference filter node. FILT1 and FILT2 provide decoupling of the reference voltage. This reference is 2.25 V. The optimal capacitor value is 0.1 μF (ceramic) and is connected between FILT1 and FILT2. FILT1 should not be used as a voltage source.
FILT2	42	O	Reference filter node. FILT1 and FILT2 provide decoupling of the reference voltage. This reference is 0 V. The optimal capacitor value is 0.1 μF (ceramic) and is connected between FILT1 and FILT2.
FSYNC	19	I/O	Frame synchronization. FSYNC indicates the beginning of a frame and the start of time slot 0. When FSYNC is sampled high on the rising edge of BCLK, the codec receives or transmits data in its specified time slot (specified by AD0 and AD1) in the frame. FSYNC is generated by the master device (output) and is an input to the slave devices. Codec 1 communicates in the first assigned time slot, followed by codec 2 communicating in the second assigned time slot.
HDINM	1	I	Headset amplifier analog inverting input. A connection between HDIN and HDOUT occurs, with selected echo gain, unless the echo gain is muted (see register 14).
HDINP	2	I	Headset amplifier analog noninverting input
HDOUTM	3	O	Inverting headset output. The HDOUTM terminal, together with the HDOUTP terminal form the differential output. With HDOUTP, a 150-Ω load can be driven differentially. HDOUTM can be used alone for single-ended operation.
HDOUTP	4	O	Noninverting headset output. HDOUTP can be used alone for single-ended operation. With HDOUTM, a 150-Ω load can be driven differentially.

NOTE 1: This device has separate analog and digital power and ground terminals. For best operation and results, the PC board design should utilize separate analog and digital power supplies, as well as separate analog and digital ground planes. Mixed-signal design practices should be used.



TLV320AIC22C

DUAL VOICE OVER INTERNET PROTOCOL (VoIP) CODEC

SPAS041B – OCTOBER 2001 – REVISED JANUARY 2003

Terminal Functions (Continued)

TERMINAL NAME	NO.	I/O	DESCRIPTION
HSINM	40	I	Handset amplifier analog inverting input. A connection between HSIN and HSOUT occurs, with selected echo gain, unless the echo gain is muted (see register 13).
HSINP	41	I	Handset amplifier analog noninverting input. A connection between the HSIN and HSOUT occurs, with programmed echo gain, unless the echo gain is muted (see register 13).
HSOUTM	38	O	Inverting handset output. The HSOUTM terminal, together with the HSOUTP terminal, forms the differential output. With HSOUTP, a 150-Ω load can be driven differentially. HSOUTM can be used alone for single-ended operation.
HSOUTP	39	O	Noninverting handset output. With HSOUTM, a 150-Ω load can be driven differentially. HSOUTP can be used alone for single-ended operation.
I ² C/SPI	14	I	I ² C/serial-port interface select. Setting this terminal high allows the user to program the registers using the I ² C interface. A low state configures the serial interface for control register programming during normal data transmission, using time slots 0 and 1. When set high (I ² C interface selected), time slots 0 and 1 in the normal data transmission are ignored.
LCDOUT	37	O	4-bit DAC output voltage, programmed through the control interface. LCDOUT can be used to provide the bias voltage for an LCD display.
LNINP	44	I	Line-port amplifier analog noninverting input (see Note 2).
LNINM	45	I	Line-port amplifier analog inverting input (see Note 2).
LNOUTM	46	O	Inverting line-port output. The LNOUTM terminal, together with the LNOUTP terminal, form the differential output. With LNOUTP, a 600-Ω load can be driven differentially. LNOUTM can be used alone for single-ended operation (see Note 2).
LNOUTP	47	O	Noninverting line-port output. With LNOUTM, a 600-Ω load can be driven differentially. LNOUTP can be used alone for single-ended operation (see Note 2).
MCLK	22	I	Master clock input. All internal clocks are derived from this clock. This clock typically is 32.768 MHz or 24.576 MHz.
MCBIAS	36	O	MCBIAS provides a bias voltage and current to operate Electret microphones. The bias voltage is specified across the microphone at 2.5 V.
MCINM	34	I	Microphone amplifier analog inverting input
MCINP	35	I	Microphone amplifier analog noninverting input
M/S	21	I	Master/slave select input. When M/S is high, the device is the master, and when it is low, it is a slave.
PWRDWN	9	I	Power down. PWRDWN is active high and when PWRDWN is pulled high, the device goes into a power-down mode that disables the output drivers and most of the high-speed clocks. The serial interface and I ² C interface are enabled. However, all register values are sustained and the device resumes full-power operation without reinitialization when PWRDWN is pulled low again. PWRDWN resets the counters only and preserves the programmed register contents.
RESET	23	I	Codec device reset. RESET initializes all device internal registers to default values when pulled low.
SCL	11	I	SCL is the serial control interface clock for the I ² C interface and is used to clock control bits into and out of the device through the SDA terminal. Tie this terminal to DV _{DD} when not used.
SDA	10	I/O	Bidirectional control data I/O line for the I ² C interface. Data is clocked into and out of the device by SCL. Tie this terminal to DV _{DD} when not used.
SPOUTP	26	O	Inverting analog output from 8-Ω speaker amplifier
SPOUTM	28	O	Noninverting analog output from 8-Ω speaker amplifier
NC	7, 8		Reserved. Leave unconnected.
V _{COM}	48	O	V _{COM} provides a reference voltage of 1.5 V. The maximum source or sink current at this terminal is 2.5 mA.
V _{SS}	24	I	Internal substrate connection. V _{SS} should be tied to AV _{SS1} and AV _{SS2} (see Note 1).

- NOTES:
- This device has separate analog and digital power and ground terminals. For best operation and results, the PC board design should utilize separate analog and digital power supplies as well as separate analog and digital ground planes. Mixed-signal design practices should be used.
 - The LNINP and LNINM are sensitive to crosstalk from LNOUTP and LNOUTM. Keep the LNOUT and LNIN signals separated on the printed circuit board. Do not route the LNOUT signals parallel to the LNIN signals.



TLV320AIC22C

DUAL VOICE OVER INTERNET PROTOCOL (VoIP) CODEC

SPAS041B – OCTOBER 2001 – REVISED JANUARY 2003

absolute maximum ratings over operating free-air temperature range (unless otherwise noted)†

Supply voltage, AV_{DD1} , AV_{DD2} , AV_{DD3} to AV_{SS1} , AV_{SS2} , AV_{SS3} , DV_{DD} to DV_{SS}	-0.3 V to 4.5 V
Analog input voltage range to AV_{SS1} , AV_{SS2} , and AV_{SS3}	-0.3 V to $AV_{DD} + 0.3$ V
Digital input voltage range	-0.3 V to $DV_{DD} + 0.3$ V
Operating virtual junction temperature range, T_J	-40°C to 150°C
Operating free-air temperature range, T_A	-40°C to 85°C
Storage temperature range, T_{stg}	-65°C to 150°C
Lead temperature 1,6 mm (1/16 inch) from case for 10 seconds	260°C

† Stresses beyond those listed under “absolute maximum ratings” may cause permanent damage to the device. These are stress ratings only, and functional operation of the device at these or any other conditions beyond those indicated under “recommended operating conditions” is not implied. Exposure to absolute-maximum-rated conditions for extended periods may affect device reliability.

recommended operating conditions

			MIN	NOM	MAX	UNIT
Supply voltage, AV_{DD1} , AV_{DD2} , AV_{DD3} , DV_{DD} (3.3-V supply)			3	3.3	3.6	V
Analog signal peak-to-peak input voltage, $V_{I(\text{analog})}$ differential	LNINP, LNINM, CIINP, CIINM	Preamp gain set to 0 dB			4	V
Analog signal peak-to-peak input voltage, $V_{I(\text{analog})}$, differential	HSINP, HSINM, HDINP, HDINM, MCINP, MCINM	Preamp gain set to 0 dB			4 (scaled by the selected gain)	V
High-level input voltage, any digital input, V_{IH}			2			V
Low-level input voltage, any digital input, V_{IL}					0.8	V
Differential output load resistance, R_L	LNOUTP, LNOUTM		600			Ω
	SPOUTP, SPOUTM		8			
	HDOUTP, HDOUTM		150			
	HSOUTP, HSOUTM		150			
Input impedance for hybrid amplifiers		LNINP, LNINM	68			k Ω
Master clock input					32.768	MHz
Load capacitance, C_L (unless otherwise specified)					20	pF
ADC or DAC conversion rate			7.2		16	kHz
Operating free-air temperature, T_A			-40		85	°C

electrical characteristics over recommended operating free-air temperature range, $DV_{DD} = 3.3$ V, $AV_{DD1} = AV_{DD2} = AV_{DD3} = 3.3$ V (unless otherwise noted)

digital inputs and outputs

PARAMETER		TEST CONDITIONS	MIN	TYP	MAX	UNIT
V_{OH}	High-level output voltage, any digital output	$I_{OH} = -360 \mu\text{A}$	2.4			V
V_{OL}	Low-level output voltage, any digital output	$I_{OL} = 2 \text{ mA}$			0.4	V
I_{IH}	High-level input current, any digital input	$V_{IH} = 3.3 \text{ V}$			10	μA
I_{IL}	Low-level input current, any digital input	$V_{IL} = 0.6 \text{ V}$			10	μA
C_i	Input capacitance, any digital input			5		pF
C_o	Output capacitance, any digital output			10		pF
I_{lkg1}	Input leakage current, any digital input (except DIN)				10	μA
I_{lkg2}	Input leakage current, DIN	$V_{IH} = 3.3 \text{ V}$			20	μA
		$V_{IL} = 0.6 \text{ V}$			60	μA
I_{OZ}	Output leakage current, any digital output				10	μA



TLV320AIC22C

DUAL VOICE OVER INTERNET PROTOCOL (VoIP) CODEC

SPAS041B – OCTOBER 2001 – REVISED JANUARY 2003

ADC dynamic performance characteristics (see Notes 3 and 4)

PARAMETER	TEST CONDITIONS	MIN	TYP	MAX	UNIT
ADC dynamic performance with line input, handset or headset selected.	$V_I = -3$ dB at input to ADC	THD	72		dB
		SNR	76		
		THD + N	70		
	$V_I = -13$ dB at input to ADC	THD	72		
		SNR	68		
		THD + N	66		
	$V_I = -43$ dB at input to ADC	THD	48		
		SNR	39		
		THD + N	38		
ADC dynamic performance with microphone input selected	$V_I = -33$ dB, Preamp gain = 0 dB, PGA gain = 0 dB	THD	60		dB
		SNR	52		
		THD + N	45		
	$V_I = -43$ dB, Preamp gain = 0 dB, PGA gain = 0 dB	THD	48		
		SNR	43		
		THD + N	41		
	$V_I = -58$ dB, Preamp gain = 0 dB, PGA gain = 0 dB	THD	34		
		SNR	28		
		THD + N	26		
ADC dynamic performance with caller ID input selected	$V_I = -13$ dB, PGA gain = 0 dB	THD	72		dB
		SNR	70		
		THD + N	68		
	$V_I = -33$ dB, PGA gain = 0 dB	THD	56		
		SNR	50		
		THD + N	48		
	$V_I = -43$ dB, PGA gain = 0 dB	THD	46		
		SNR	38		
		THD + N	36		

NOTES: 3. The test condition is a 1020-Hz input signal with an 8-kHz conversion rate. Input and output common mode is 1.5 V.
 4. The input level corresponds to TSNR mask corner points in specification G.712.

TLV320AIC22C

DUAL VOICE OVER INTERNET PROTOCOL (VoIP) CODEC

SPAS041B – OCTOBER 2001 – REVISED JANUARY 2003

ADC channel transfer response characteristics over recommended ranges of supply voltage and operating free-air temperature, when selecting handset or headset as input

PARAMETER	TEST CONDITIONS	MIN	TYP	MAX	UNIT
Gain relative to gain at 1020 Hz	Preamp gain = 0 dB, PGA gain = 0 dB, Sampling rate = 8 kHz (see Note 5)	0 Hz to 60 Hz		-26	dB
		200 Hz	-1.8	0.35	
		300 Hz to 3 kHz	-0.25	0.25	
		3.3 kHz	-0.35	0.25	
		3.4 kHz	-0.9	-0.25	
		4 kHz		-25	
		4.6 kHz to 8 kHz		-60	
	Above 8 kHz		-55		
	Preamp gain = 0 dB, PGA gain = 0 dB, Sampling rate = 16 kHz (see Note 6)	0 Hz to 120 Hz		-26	
		400 Hz	-1.8	0.35	
		600 Hz to 6 kHz	-0.25	0.25	
		6.6 kHz	-0.35	0.25	
		6.8 kHz	-0.9	0.25	
		8 kHz		-25	
9.2 kHz to 16 kHz			-60		
Above 16 kHz		-55			

NOTES: 5. When the high-pass filter (HPF) is bypassed, the passband is 0 Hz to 3 kHz. When the HPF is inserted, the passband is 300 Hz to 3 kHz.

6. When the HPF is bypassed, the passband is 0 Hz to 6 kHz. When the HPF is inserted, the passband is 600 Hz to 6 kHz.

ADC channel passband frequency characteristics with microphone selected as input

PARAMETER	TEST CONDITIONS	MIN	TYP	MAX	UNIT
Gain relative to gain at 1020 Hz (see Note 5)	Preamp gain = 0 dB, PGA gain = 0 dB, Sampling rate = 8 kHz	300 Hz to 3 kHz	-0.25	0.25	dB
		3.3 kHz	-0.4	0.25	
		3.4 kHz	-0.9	-0.25	
Gain relative to gain at 1020 Hz (see Note 6)	Preamp gain = 0 dB, PGA gain = 0 dB, Sampling rate = 16 kHz	600 Hz to 6 kHz	-0.25	0.25	dB
		6.6 kHz	-0.5	0.25	
		6.8 kHz	-1	0.25	

NOTES: 5. When the high-pass filter (HPF) is bypassed, the passband is 0 Hz to 3 kHz. When the HPF is inserted, the passband is 300 Hz to 3 kHz.

6. When the HPF is bypassed, the passband is 0 Hz to 6 kHz. When the HPF is inserted, the passband is 600 Hz to 6 kHz.

ADC channel passband frequency characteristics with line input selected

PARAMETER	TEST CONDITIONS	MIN	TYP	MAX	UNIT
Gain relative to gain at 1020 Hz (see Note 5)	PGA gain = 0 dB, Sampling rate = 8 kHz, Pole select = 64, 32, 21.3, or 16 kHz	300 Hz to 3 kHz	-0.25	0.25	dB
		3.3 kHz	-0.4	0.25	
		3.4 kHz	-0.9	0.25	
Gain relative to gain at 1020 Hz (see Note 6)	PGA gain = 0 dB, Sampling rate = 16 kHz, Pole select = 64, 32, 21.3, or 16 kHz	600 Hz to 6 kHz	-0.65	0.25	dB
		6.6 kHz	-0.9	0.25	
		6.8 kHz	-1.5	-0.25	

NOTES: 5. When the high-pass filter (HPF) is bypassed, the passband is 0 Hz to 3 kHz. When the HPF is inserted, the passband is 300 Hz to 3 kHz.

6. When the HPF is bypassed, the passband is 0 kHz to 6 kHz. When the HPF is inserted, the passband is 600 Hz to 6 kHz.



ADC characteristics

PARAMETER		TEST CONDITIONS	MIN	TYP	MAX	UNIT
$V_{I(PP)}$	Peak-input voltage, differential	Preamp gain = 0 dB			4	V
Interchannel and intrachannel isolation (see Note 2)		Any input to any input, any input to any output	80			dB
E_G	Gain error (with respect to ideal gain)	Valid for HSIN, HDIN, and MCIN			1	dB
		Valid for LNIN	$V_I = 1020$ Hz PGA gain = 0 dB	-4	1.5	dB
		Valid for CIIN		-1.5	4	dB
$E_{O(ADC)}$	ADC channel offset error			50	mV	
CMRR	Common-mode rejection ratio	Preamp = 0 dB PGA = 0 dB	40			dB
Idle channel noise		Preamp = 0 dB PGA = 0 dB		30	75	μ V rms
Channel delay (HPF bypassed)				$20/f_S$		s
PGA step error		$V_I = 1020$ Hz	-0.5		0.5	dB

NOTE 2: The LNINP and LNINM are sensitive to crosstalk from LNOUTP and LNOUTM. Keep the LNOUT and LNIN signals separated on the printed circuit board. Do not route the LNOUT signals parallel to the LNIN signals.

callerID frequency response characteristics (see Figure 1)

PARAMETER		TEST CONDITIONS	MIN	TYP	MAX	UNIT
$f_{co(L)}$	Low-cutoff frequency	Connected as shown in Figure 23 (see Note 7)		570		Hz
A_p	Passband gain at 2 kHz			1.5		dB
Attenuation from input to IC terminal at 60 Hz				-44		dB

NOTE 7: All values are applicable when used with external components as shown in Figure 23.

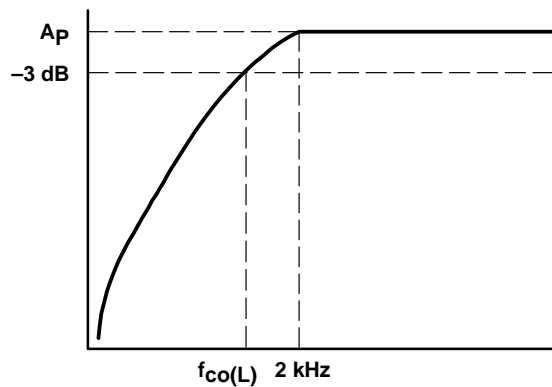

Figure 1. Caller ID Frequency Response

TLV320AIC22C

DUAL VOICE OVER INTERNET PROTOCOL (VoIP) CODEC

SPAS041B – OCTOBER 2001 – REVISED JANUARY 2003

DAC dynamic performance characteristics (THD and SNR calculated with bandwidth = $F_s/2$)

PARAMETER	TEST CONDITIONS	MIN	TYP	MAX	UNIT
DAC dynamic performance with handset or headset drivers (HSOUT or HDOOUT) (see Note 4)	$V_I = -3$ dBr (see Note 8)	THD	72		dB
		SNR	76		
		THD + N	70		
	$V_I = -9$ dBr (see Note 8)	THD	72		
		SNR	68		
		THD + N	66		
	$V_I = -43$ dBr (see Note 8)	THD	50		
		SNR	37		
		THD + N	36		
DAC dynamic performance with 8- Ω driver (SPOUT) (see Note 4)	$V_I = -3$ dBr (see Note 9)	THD	60		dB
		SNR	65		
		THD + N	60		
	$V_I = -13$ dBr (see Note 9)	THD	55		
		SNR	58		
		THD + N	54		
	$V_I = -43$ dBr (see Note 9)	THD	38		
		SNR	36		
		THD + N	35		
DAC dynamic performance with line-output driver (LNOUT), 16-kHz pole selected, 1000-Hz input signal (see Note 4)	$V_I = -3$ dBr (see Note 8)	THD	72		dB
		SNR	76		
		THD + N	70		
	$V_I = -13$ dBr (see Note 8)	THD	72		
		SNR	72		
		THD + N	70		
	$V_I = -43$ dBr (see Note 8)	THD	50		
		SNR	44		
		THD + N	42		
DAC dynamic performance with line-output driver (LNOUT), 64-kHz pole selected, 1000-Hz input signal (see Note 4)	$V_I = -3$ dBr (see Note 8)	THD	72		dB
		SNR	76		
		THD + N	70		
	$V_I = -13$ dBr (see Note 8)	THD	72		
		SNR	70		
		THD + N	68		
	$V_I = -43$ dBr (see Note 8)	THD	50		
		SNR	44		
		THD + N	42		

- NOTES: 4. The input level corresponds to TSNR mask corner points in specification G.712.
8. The input signal is the digital equivalent of a sine wave (digital full scale = 0 dBr). A 0-dBr or full-scale digital input results in a 4-V(p-p) differential output.
9. The input signal is the digital equivalent of a sine wave (digital full scale = 0 dBr). A 0-dBr or full-scale digital input results in a 5-V(p-p) differential output.



TLV320AIC22C

DUAL VOICE OVER INTERNET PROTOCOL (VoIP) CODEC

SPAS041B – OCTOBER 2001 – REVISED JANUARY 2003

DAC channel transfer response characteristics over recommended ranges of supply voltage and operating free-air temperature (see Note 8), with DAC connected to handset (HSOUT) or headset (HDOUT) drivers

PARAMETER	TEST CONDITIONS	MIN	TYP	MAX	UNIT	
Gain relative to gain at 1020 Hz	Sampling rate = 8 kHz	0 Hz to 3 kHz	-0.25		0.25	dB
		3.3 kHz	-0.35		0.25	
		3.4 kHz	-0.9		-0.25	
		4 kHz			-25	
		4.6 kHz and above			-68	
	Sampling rate = 16 kHz	0 Hz to 6 kHz	-0.25		0.25	
		6.6 kHz	-0.35		0.25	
		6.8 kHz	-0.9		-0.25	
		8 kHz			-25	
		9.2 kHz and above			-68	

NOTES: 8. The input signal is the digital equivalent of a sine wave (digital full scale = 0 dB_r). A 0-dB_r or full-scale digital input results in a 4-V_(P-P) differential output.

DAC channel passband frequency characteristics with DAC connected to 8-Ω speaker driver (SPOUT) (see Note 9)

PARAMETER	TEST CONDITIONS	MIN	TYP	MAX	UNIT	
Gain relative to gain at 1020 Hz	Sampling rate = 8 kHz	0 Hz to 3 kHz	-0.28		0.25	dB
		3.3 kHz	-0.4		0.15	
		3.4 kHz	-1.2		0.25	
	Sampling rate = 16 kHz	0 Hz to 6 kHz	-0.7		0.25	
		6.6 kHz	-0.8		0.25	
		6.8 kHz	-1.35		-0.1	

NOTES: 9. The input signal is the digital equivalent of a sine wave (digital full scale = 0 dB_r). A 0-dB_r or full-scale digital input results in a 5-V_(P-P) differential output.

DAC channel passband frequency characteristics with DAC connected to line output driver (LNOU) (see Note 8 and Note 10)

PARAMETER	TEST CONDITIONS	MIN	TYP	MAX	UNIT	
Gain relative to gain at 1.02 kHz	Sampling rate = 8 kHz, Pole select = 64 kHz, 32 kHz, 21.3 kHz, or 16 kHz	0 Hz to 3 kHz	-0.25		0.25	dB
		3.3 kHz	-0.35		0.25	
		3.4 kHz	-1.0		0.25	
	Sampling rate = 16 kHz, Pole select = 64 kHz, 32 kHz, or 21.3 kHz	0 Hz to 6 kHz	-0.47		0.25	
		6.6 kHz	-0.63		0.25	
		6.8 kHz	-1.16		0.25	
	Sampling rate = 16 kHz, Pole select = 16 kHz	0 Hz to 6 kHz	-0.7		0.25	
		6.6 kHz	-0.9		0.25	
		6.8 kHz	-1.45		0.25	

NOTES: 8. The input signal is the digital equivalent of a sine wave (digital full scale = 0 dB_r). A 0-dB_r or full-scale digital input results in a 4-V_(P-P) differential output.

10. The filter gain is measured with respect to the gain at 1020 Hz.



TLV320AIC22C

DUAL VOICE OVER INTERNET PROTOCOL (VoIP) CODEC

SPAS041B – OCTOBER 2001 – REVISED JANUARY 2003

line output out-of-band performance characteristics

PARAMETER	TEST CONDITIONS	MIN	TYP	MAX	UNIT
Line output out-of-band performance	Noise measured in 1-kHz bandwidth from 4.6 kHz to 300 kHz; -10-dB input signal; PGA gain = 0 dB, Output load = 600 Ω				$\mu\text{V}/\sqrt{\text{Hz}}$
		Pole select = 64 kHz		32	
		Pole select = 32 kHz		20	
		Pole select = 21.3 kHz		14	
				11	

DAC characteristics

PARAMETER	TEST CONDITIONS	MIN	TYP	MAX	UNIT
Interchannel and intrachannel isolation	Any input to any output, any output to any output	80			dB
E_G Gain error (with respect to ideal gain)	$V_I = 1020$ Hz	-0.5		0.5	dB
Idle channel noise	$f_s/2$		30	75	$\mu\text{V rms}$
Channel delay			$21/f_s$		s
V_O	Analog output voltage (SPOUTP-SPOUTM)		± 2.5		$V_{(P-P)}$
	Analog output voltage (handset/headset and line interfaces)		± 2		
PGA step error	Input signal = 1020 Hz	-0.5		0.5	dB

NOTES: 11 This amplifier should be used only in differential mode.

12 Common mode: 1.5 V

power-supply rejection characteristics (see Note 13)

PARAMETER	TEST CONDITIONS	MIN	TYP	MAX	UNIT
$V_{DD(1)}$ Supply-voltage rejection ratio, ADC channel, AV_{DD1} , and AV_{DD2}	$f_I = 0$ to $f_s/2$			-50	dB
$V_{DD(4)}$ Supply-voltage rejection ratio, DAC channel	$f_I = 0$ to 30 kHz			-50	dB

NOTE 13 Power-supply rejection measurements are made with both the ADC and the DAC channels idle and a 200-mV peak-to-peak signal applied to the appropriate supply.

power supply characteristics

PARAMETER	TEST CONDITIONS	MIN	TYP	MAX	UNIT
$I_{DD(\text{analog})}$ Codec power-supply current, analog (including drivers); AV_{DD1} , AV_{DD2}	Operating		30.8	61.5	mA
$I_{DD(\text{analog})}$ Codec power-supply current, analog	Analog master power down			1.5	mA
$I_{DD(\text{digital})}$ Codec power-supply current, digital; DV_{DD}	Operating			6.5	mA
$I_{DD(\text{digital})}$ Codec power-supply current, digital (hardware power-down mode)	PWRDWN terminal = logic 1		2.2	5	mA
$I_{DD(\text{speaker})}$ Power-supply current, 8- Ω speaker driver; AV_{DD3}	Operating		200	400	mA
$I_{DD(\text{quiescent})}$ 8- Ω driver dc current without swing at output; AV_{DD3}				2	mA
$I_{DD(\text{analog})}$ Codec power-supply current, analog (hardware power-down mode)	PWRDWN terminal = logic 1			100	μA



TLV320AIC22C

DUAL VOICE OVER INTERNET PROTOCOL (VoIP) CODEC

SPAS041B – OCTOBER 2001 – REVISED JANUARY 2003

speaker driver characteristics

PARAMETER		TEST CONDITIONS	MIN	TYP	MAX	UNIT
$V_{N(PP)}$	Output peak-to-peak voltage (between SPOUTP and SPOUTM)	$AV_{DD3} = 3.3\text{ V}$, Fully differential, 8- Ω load, 0 dBr = full-scale digital input		5		V(P-P)
V_{OO}	Output offset voltage	Fully differential		± 5		mV
	Output power (peak)	$R_L = 8\ \Omega$, $AV_{DD3} = 3.3\text{ V}$			390	mW
	Mute		80			dB
	Maximum capacitive load				25	pF

handset and headset driver characteristics

PARAMETER		TEST CONDITIONS	MIN	TYP	MAX	UNIT
$V_{N(PP)}$	Output peak-to-peak voltage	AV_{DD1} , $AV_{DD2} = 3.3\text{ V}$, Fully differential, 150- Ω load		4		V
V_{OO}	Output offset voltage	Fully differential		± 5		mV
	Maximum capacitance load				100	pF
	Mute		80			dB
	Maximum resistive load				150	Ω

line driver characteristics

PARAMETER		TEST CONDITIONS	MIN	TYP	MAX	UNIT
$V_{N(PP)}$	Output peak-to-peak voltage	AV_{DD1} , $AV_{DD2} = 3.3\text{ V}$, Fully differential, 600- Ω load, 0-dB gain		4		V
V_{OO}	Output offset voltage	Fully differential		± 5		mV
	Maximum capacitive load for LNOUT				25	pF
	Maximum resistive load for LNOUT				600	Ω
	Mute (neither DAC connected to line driver)		80			dB

4-bit DAC characteristics

PARAMETER		TEST CONDITIONS	MIN	TYP	MAX	UNIT
V_O	Output voltage	AV_{DD1} , $AV_{DD2} = 3.3\text{ V}$	0		3	V
	Linearity			± 0.5		LSB
	Output load				600	Ω
					20	pF
t_s	Settling time			50		μs



TLV320AIC22C

DUAL VOICE OVER INTERNET PROTOCOL (VoIP) CODEC

SPAS041B – OCTOBER 2001 – REVISED JANUARY 2003

mic bias characteristics

PARAMETER		TEST CONDITIONS	MIN	TYP	MAX	UNIT
V_O	Output voltage	At MCBIAS terminal, Sourcing 4 mA	2.3		2.7	V
I_O	Output current, max	Source only		4		mA
	Output noise	20 Hz to 20 kHz			60	μVrms
	Output PSRR	Up to 8 kHz			-60	dB

timing requirements

MCLK

PARAMETER		TEST CONDITIONS	MIN	TYP	MAX	UNIT
f	Frequency			32.768 or 24.576	32.768	MHz
	Accuracy			± 200		ppm
	Duty cycle		40%	50%	60%	
t_r	Rise time			8		ns
t_f	Fall time			8		ns

timing requirements

digital I/O timing (see Figure 2)

PARAMETER		TEST CONDITIONS	MIN	TYP	MAX	UNIT
$t_{d(1)}$	Delay time, BCLK \uparrow to FSYNC \uparrow (slave mode)				15	ns
$t_{d(3)}$	Delay time, MCLK \uparrow to BCLK \uparrow (slave mode)				29	ns
$t_{su(1)}$	Setup time, DIN valid before BCLK \downarrow		10			ns
$t_{h(1)}$	Hold time, DIN valid after BCLK \downarrow		9			ns

switching characteristics

digital I/O timing (see Figure 2)

PARAMETER		TEST CONDITIONS	MIN	TYP	MAX	UNIT
$t_{d(1)}$	Delay time, BCLK \uparrow to FSYNC \uparrow (master mode)		5		10	ns
$t_{d(2)}$	Delay time, BCLK \uparrow to DOUT valid	$C_L = 20 \text{ pF}$			25	ns
$t_{d(6)}$	Delay time, BCLK \uparrow to FSYNC \downarrow		3			ns
$t_{d(4)}$	Delay time, BCLK \downarrow to to DOUT invalid			BCLK low time/ $2 + t_{d(2)}$		ns
$t_{d(5)}$	Delay time, BCLK \uparrow to DOUT high impedance following last data-bit transfer				25	ns
$t_{d(3)}$	Delay time, MCLK \uparrow to BCLK \uparrow (master mode)		13		29	ns

reset timing

PARAMETER		TEST CONDITIONS	MIN	TYP	MAX	UNIT
t_w	$\overline{\text{RESET}}$ pulse width		$2/\text{MCLK}$			ns
$t_{h(r)}$	Wait time after $\overline{\text{RESET}}$			10		μs



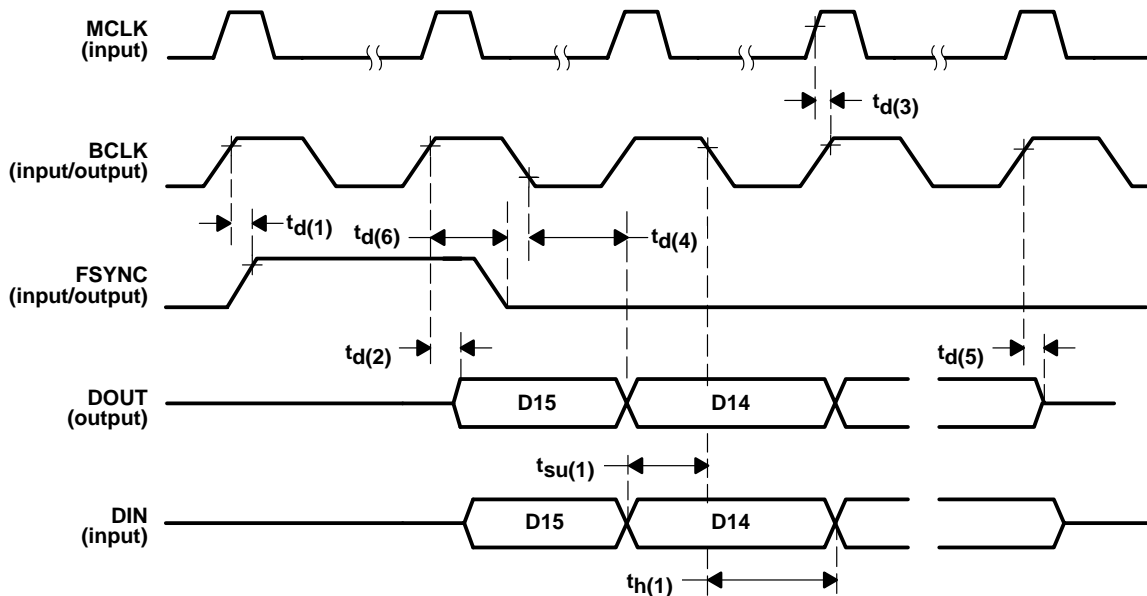

Figure 2. Digital I/O Timing for Data Channel

TLV320AIC22C

DUAL VOICE OVER INTERNET PROTOCOL (VoIP) CODEC

SPAS041B – OCTOBER 2001 – REVISED JANUARY 2003

detailed description

codecs

There are two codecs on the TLV320AIC22C that can be connected to any of the analog inputs or outputs via the internal analog crosspoint. The codecs are full 8-bit pulse-coded modulation (PCM) companded or 16-bit linear codecs that meet G.711 standards and include transmit band-pass and receive low-pass filters (LPFs). A-law/ μ -law companding or linear coding and -36 dB to 12 dB of analog gain adjustment, in steps of 1.5 dB for each path, are selectable via the I²C or serial interface. These modes can be selected by programming the appropriate register. In the 8-bit PCM companded mode, the data is zero padded to 15 bits and the 16th bit serves as the valid data bit.

analog crosspoint

The internal analog crosspoint is a lossless analog switch matrix controlled via the I²C or serial interface. The analog crosspoint allows any source device to be connected to any sink device. Additionally, special summing connections with adjustable loss are included to implement sidetone for the handset and headset ports. A muting function is included on any of the sink devices. The control for the analog crosspoint, defined in the register map, is implemented in such a way that a particular analog input or output can be connected to a codec by setting a single bit. This implies that more than one analog input or output can be connected to a codec at one time. Full performance is ensured for two or fewer inputs and outputs connected to a codec, except in the case of the line output. Connecting the output of both codecs to the line output (LNOUTP and LNOUTM) is not allowed.

ADC channel

The ADC channel consists of a PGA, an antialiasing filter, a sigma-delta ADC, and a decimation filter. The ADC is an oversampling sigma-delta modulator. The ADC provides high resolution and low-noise performance using oversampling techniques and the noise-shaping advantages of sigma-delta modulators.

The analog input signals are amplified and filtered by on-chip buffers and an antialiasing filter before being applied to ADC input. The ADC converts the signal into discrete-output digital words in 2s-complement format, corresponding to the analog signal value at the sampling time.

The decimation filter reduces the digital data rate to the sampling rate. This is accomplished by decimating with a ratio equal to the oversampling ratio. The output of this filter is a 15-bit 2s-complement data word, clocking at the selected sample rate. The 16th bit is a data-valid flag.

These 15-bit digital words, representing sampled values of the analog input signal, are sent to the host via the serial-port interface. If the ADC reaches its maximum value, a control register flag is set. This bit can be read only via the serial port. The analog-to-digital and digital-to-analog conversions are synchronous.

The digital conversion data is transmitted out of the device via the serial interface, with the data-valid flag being transmitted first, followed by the MSB of the conversion data. Data is transmitted on the rising edge of BCLK.

The bandwidth of the codec is 3.6 kHz for a sampling rate of 8 kHz, and 7.2 kHz for a sampling rate of 16 kHz. The gain of the ADC input amplifier is programmed in register 3 for codec 1 and register 8 for codec 2.

The ADC channel contains an HPF that suppresses power-line frequencies, which can be bypassed by programming the appropriate bits in registers 15 and 16 for codec 1 or codec 2, respectively.



DAC channel

The DAC channel consists of an interpolation filter, a sigma-delta DAC, LPF, and a PGA. The DAC is an oversampling sigma-delta modulator. The DAC performs high-resolution, low-noise, digital-to-analog conversion using oversampling sigma-delta techniques.

The DAC receives 16-bit data words (2s complement) from the host via the serial-port interface. Data is latched on the falling edge of BCLK. The most significant bit (MSB) of the digital data is transmitted to the DAC first, ending with the LSB as the last bit.

The data is converted to an analog voltage by the sigma-delta DAC, comprising a digital interpolation filter and a digital modulator. The interpolation filter resamples the digital data at a rate of N times the incoming sample rate, where N is the oversampling ratio. The high-speed data output from this filter is applied to the sigma-delta DAC.

The DAC output is passed to an internal LPF to complete the signal reconstruction, resulting in an analog signal. This analog signal is buffered and amplified by a differential output driver capable of driving the required load. The gain of the DAC output amplifier is programmed in register 4 for codec 1 and register 9 for codec 2.

analog and digital loopback

The test capabilities include an analog loopback and a digital loopback. The loopbacks allow the user to test the ADC/DAC channels and can be used for in-circuit system-level tests. The digital loopback feeds the ADC output to the DAC input on the device. The analog loopback loops the DAC output back into the ADC input.

power down and reset

When the power-down (PWRDWN) terminal is pulled high, the device goes into a power-down mode, where the required analog power-supply current drops to approximately 100 μ A and the digital power-supply current drops to approximately 2 mA. This is called the hardware power-down mode†. The serial interface and I²C interface are still enabled. All register values are sustained and the device resumes full-power operation without reinitialization when PWRDWN is pulled low again. PWRDWN resets the counters only and preserves the programmed register contents. After PWRDWN has been pulled low, the user must wait at least two frame synchronizations before communicating control or conversion information.

Software control can be used to power down individual codecs. Each codec contains an ADC, a DAC, and a digital filter. Codec power down resets all internal counters, but leaves the contents of the programmable control registers unchanged. Analog circuitry and the analog power-supply current are not affected when programming codec power-down mode. Codec power down is achieved by programming register 2 for codec 1 and register 7 for codec 2.

An analog master power down can be initiated via software control by programming register 14. Analog master power down is used to power down all of the analog circuitry within the device. This mode is similar to hardware power down in that the required analog power-supply current drops to approximately 100 μ A.

Table 1 shows the state of the terminals during codec power down and hardware power down.

†To obtain the low analog power-down current, the clock should not be running.

TLV320AIC22C

DUAL VOICE OVER INTERNET PROTOCOL (VoIP) CODEC

SPAS041B – OCTOBER 2001 – REVISED JANUARY 2003

Table 1. Terminal States During Hardware and Codec Power Down

TERMINAL NAME	STATE DURING CODEC POWER DOWN	STATE DURING HARDWARE POWER DOWN
HDOUTM	Internal common-mode voltage (1.5 V)	Floating
HDOUTP	Internal common-mode voltage (1.5 V)	Floating
SPOUTP	Internal common-mode voltage (1.5 V)	Floating
SPOUTM	Internal common-mode voltage (1.5 V)	Floating
HSOUTM	Internal common-mode voltage (1.5 V)	Floating
HSOUTP	Internal common-mode voltage (1.5 V)	Floating
LNOUTM	Internal common-mode voltage (1.5 V)	Floating
LNOUTP	Internal common-mode voltage (1.5 V)	Floating
HDINP	Normal operation	Floating
HDINM	Normal operation	Floating
MCINP	Normal operation	Floating
MCINM	Normal operation	Floating
HSINM	Normal operation	Floating
HSINP	Normal operation	Floating
LNIN	Normal operation	Floating
LNINM	Normal operation	Floating
LCDOUT	Normal operation	Floating
MCBIAS	Normal operation	Floating
PWRDWN	Normal operation	Normal operation
SDA	Normal operation	Normal operation
SCL	Normal operation	Normal operation
AD1	Normal operation	Normal operation
AD0	Normal operation	Normal operation
I ² C/SPI	Normal operation	Normal operation
DOUT	Normal operation	Normal operation
DIN	Normal operation	Logic high
FSYNC	Normal operation	Normal operation
BCLK	Normal operation	Normal operation
VCOM	Normal operation	Floating
M/S	Normal operation	Normal operation
CIINP		Pulled to AV _{SS1} /AV _{SS2} through 40 kΩ
CIINM		Pulled to AV _{SS1} /AV _{SS2} through 40 kΩ



power down and reset (continued)

The capability to individually power down each output driver also is present. Table 2 shows the typical power savings that can be achieved if the associated driver is powered down.

Table 2. Powering Down Individual Drivers

DRIVER POWERED DOWN	REGISTER USED TO POWER DOWN DRIVER	TYPICAL POWER SAVINGS WHEN OUTPUT POWERED DOWN
Handset	13	3.2 mA
Headset	14	3.2 mA
Speaker	11	1 mA
Line output	14	2.5 mA

There are two ways to reset the TLV320AIC22C:

- By pulling $\overline{\text{RESET}}$ low, or
- By writing to the software reset bits in control registers 2 and/or 7 to reset either codec

Asserting $\overline{\text{RESET}}$ low puts the device into a default state with default register settings. After deasserting $\overline{\text{RESET}}$, the user should wait a minimum of 10 μs before sending control or conversion data to the device.

The default register settings are described in the sections titled *suggested configuration sequence* and *register map*. After a software reset has been removed, control and conversion data can be sent in the next frame.

Asserting a software reset by programming register 2 puts registers 1–5 and 15 in their default settings and resets codec 1.

Asserting a software reset by programming register 7 puts registers 6–14, 16, and 17 in their default settings and resets codec 2.

microphone bias

To operate Electret microphones properly, a bias voltage and current are provided. Typically, the current drawn by the microphone is on the order of 100 μA to 800 μA , and the bias voltage is specified across the microphone at 2.5 V. The bias has good power-supply noise rejection in the audio band, can source 4-mA maximum current, and can be shared between all the microphones.

TLV320AIC22C

DUAL VOICE OVER INTERNET PROTOCOL (VoIP) CODEC

SPAS041B – OCTOBER 2001 – REVISED JANUARY 2003

microphone amplifiers

There are three microphone preamplifiers, one each for the handset, headset, and speakerphone microphones. The input signals for the handset and headset amplifiers typically are less than 20 mVrms, 100 mV max. The input signals for the speakerphone amplifier typically are less than 2 mVrms, 20 mV max. The amplifiers have a differential input to minimize noise and electromagnetic compatibility (EMC) immunity problems. Three values for the gain for the handset and headset microphones and four values for the gain for the speakerphone microphone are selectable via the I²C or serial interface to meet the requirements in Europe and North America. The frequency response is flat, up to 8 kHz.

Table 3. Gain Settings

INPUT	GAIN SETTINGS
Handset microphone preamplifier (HSINP,M)	0 dB, 14 dB, 23 dB, or mute
Headset microphone preamplifier (HDINP,M)	0 dB, 14 dB, 23 dB, or mute
Speakerphone microphone preamplifier (MCINP,M)	0 dB, 20 dB, 32 dB, 42 dB, or mute

By default, the echo gain for the handset and headset are 14 dB. Therefore, a connection exists between the handset and headset inputs (microphones) and their respective outputs (speakers) to implement sidetone.

driver amplifiers

There are two driver amplifiers that are meant to drive a 150-Ω handset or headset speaker, differentially. The drive amplifier is differential to minimize noise and EMC immunity problems. The frequency response is flat, up to 8 kHz.

speakerphone amplifiers

The speakerphone speaker impedance is 8 Ω. The drivers are capable of providing a 5-V peak-to-peak differential signal, which means that the peak power is about 390 mW. To achieve this and to minimize noise and EMC immunity problems, the drive amplifier is differential. The frequency response is flat, up to 8 kHz.

4-bit DAC

The 4-bit DAC can be used to provide bias to any component on the board, such as a liquid crystal display (LCD). The output of the 4-bit DAC is controlled through the I²C or the serial interface by writing to the four LSBs of control register 12. The register uses 2s-complement data. The DAC has a settling time of about 5 μs, a linearity of ±0.5 LSB, and is a voltage-output DAC. It provides a maximum output of 3 V. For a 16-character by 2-line LCD display module, the contrast control requires 0.2 mA. The input codes and the corresponding output voltages at the LCDOUT terminal are shown in Table 4.



Table 4. 4-Bit DAC Input Code vs Output Voltage

INPUT VALUE (DECIMAL)	INPUT CODE (2S COMPLEMENT) D3–D0	OUTPUT VOLTAGE
7	0111	2.8125
6	0110	2.625
5	0101	2.4375
4	0100	2.25
3	0011	2.0625
2	0010	1.875
1	0001	1.6875
0	0000	1.5
–1	1111	1.3125
–2	1110	1.125
–3	1101	0.9375
–4	1100	0.75
–5	1011	0.5625
–6	1010	0.375
–7	1001	0.1875
–8	1000	0

caller ID amplifier

The caller ID amplifier has a fixed 0-dB gain (typ), attenuates the low-frequency ring signal, and isolates from the line. This input also can be connected to the ADC via the analog crosspoint.

line ports

The line ports can be connected, via a transformer, to a telephone line. The driver stage is capable of driving a 600-Ω load, differentially, to near rail-to-rail swing. This stage is implemented such that the resistors and capacitors are integrated. Signal levels at the input terminals can be as high as 1.4 Vrms (2 V). The analog pole select option (register 14) allows the user to select the position of the filter pole for the line input and output.

serial interface

The serial interface is designed to provide glueless interface to the McBSP of a TMS320C54x™ or TMS320C6x DSP. This interface is used primarily for transferring ADC and DAC data. However, control register information also can be transferred, refer to *register programming using the serial interface*. The serial interface is a 4-line interface consisting of:

- BCLK – bit clock used to transmit and receive data bits
- FSYNC – frame-synchronization signal that denotes the start of a new frame of data
- DOUT – output serial data used to transfer ADC data and register information to the attached DSP
- DIN – input serial data used to transfer DAC data and register control information from the attached DSP

The TLV320AIC22C can be configured as a master or a slave (see the *master/slave functionality* section for a detailed description). When configured as a master device, FSYNC and BCLK are generated by the master codec and input to the DSP.

Data is received and transmitted in frames consisting of 256 BCLKs, which is 16, 16-bit time slots. Each frame is subdivided into time slots consisting of 16 BCLKs per time slot. In each frame, two time slots are reserved for control register information and eight time slots are reserved for codec data. The remaining six time slots are unused. A pulse on FSYNC indicates the beginning of a frame.



TLV320AIC22C

DUAL VOICE OVER INTERNET PROTOCOL (VoIP) CODEC

SPAS041B – OCTOBER 2001 – REVISED JANUARY 2003

serial interface (continued)

The control information is valid only when the serial interface has been selected by connecting the I²C/SPI terminal to logic 0. The frame format is shown in Figure 3, and the timing diagram for the frame is shown in Figure 4.

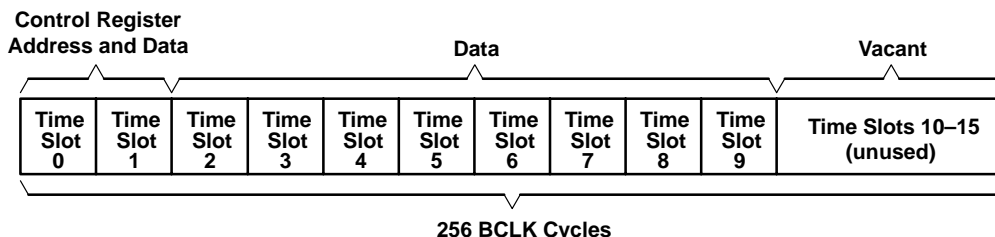

Figure 3. Frame Format Used by the TLV320AIC22C

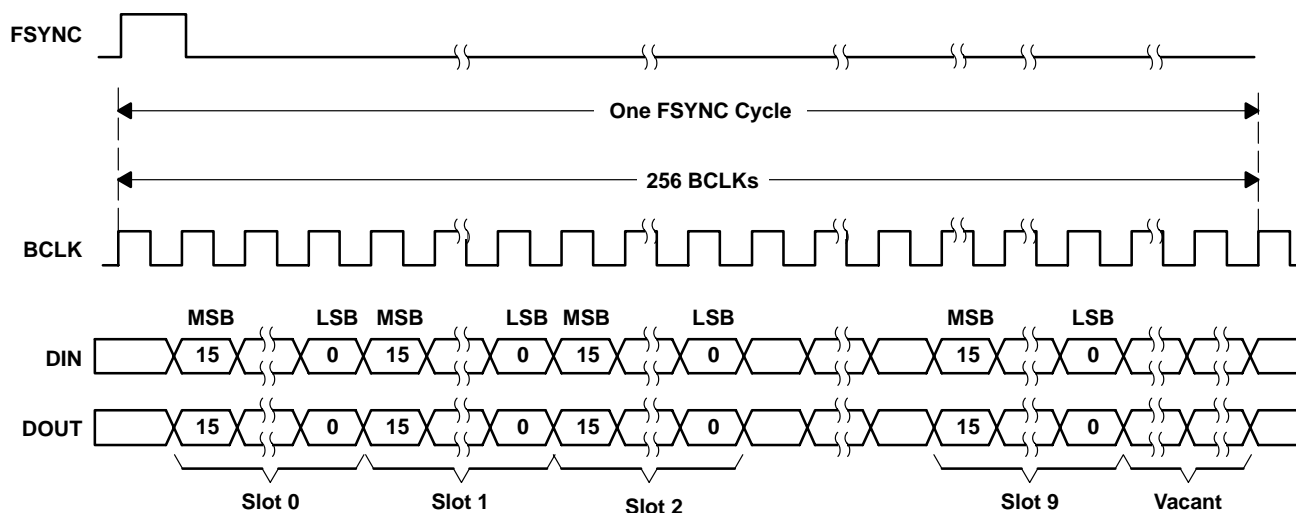

Figure 4. TLV320AIC22C Frame Format Timing

When the serial interface is selected for control (I²C/SPI set to logic 0), the first two time slots after the FSYNC pulse (time slots 0 and 1) are used for sending and receiving control data. The next eight slots are used for actual conversion data sent and received by the codec.

Each time slot is 16 bits wide. Data bytes are sent with the first bit representing the MSB. Transmitted data is sent on the rising edge of BCLK, and data being received is latched on the falling edge of BCLK.

control register address and data

When I²C/SPI is tied to a logic low, the serial interface is selected for controlling the device. Control information is sent and received in time slots 0 and 1. An active-high pulse on FSYNC indicates the start of a frame. The structure of time slots 0 and 1 is shown in Figures 5 and 6. Bit 15 (the MSB) is transmitted or received first. Transmitted data is sent on the rising edge of BCLK and data being received is latched on the falling edge of BCLK.

Time slot 0 indicates:

- If a read or write operation is occurring
- Which device is being accessed
- The register address within the device being accessed

AD0 (LSB) and AD1 (MSB) form the device address. Up to four TLV320AIC22C devices can be addressed, with addresses ranging from 0 to 3. The five LSBs in time slot 0 are unused.

Slot 0:		
B15	Read/write control	1 = Write, 0 = Read
B14	AD1 device address bit (MSB)	
B13	AD0 device address bit (LSB)	
B12–B5	Register address (8 bits)	
B4–B0	Unused	



NOTE A: The register address is the binary equivalent of the register number.

Figure 5. Bit Assignment and Definition for Slot 0 Word

If bit 15 in slot 0 is a 1, a write operation has been requested by the DSP. The DSP drives data onto the DIN terminal in the next time slot (time slot 1) as follows:

- The eight bits of data to be written into the register appear on the first eight bits, with the MSB appearing first.
- The next eight bits (eight LSBs) are unused.

If bit 15 in slot 0 is a 0, a read operation has been requested. The TLV320AIC22C compares the values of the device address bits, bits 14 and 13 of time slot 0 (AD1 and AD0 bits) to the configuration of the AD1 and AD0 terminals on the device to determine if it is the device being addressed. The device drives data on DOUT if it is the addressed device as follows:

- The 8 bits of data from the addressed register appear in the first eight bits, with the MSB appearing first.
- The next eight bits (eight LSBs) are unused.

Slot 1:	
B15–B8	Control register data
B7–B0	Unused

TLV320AIC22C

DUAL VOICE OVER INTERNET PROTOCOL (VoIP) CODEC

SPAS041B – OCTOBER 2001 – REVISED JANUARY 2003

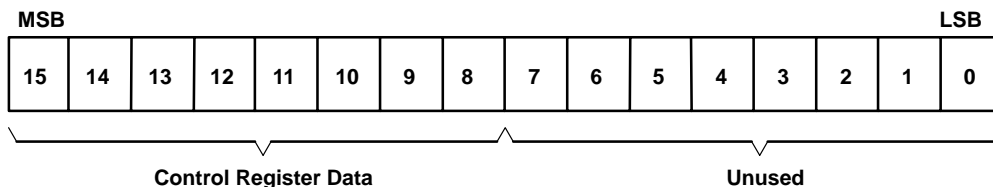

- NOTES:
- A. If the register address is 0x00h, no register is updated.
 - B. The default condition is for control information to be updated every frame. If control information is not to be updated every frame, register 17 can be programmed to cause the control slots to appear with N frames of empty control slots between them. The contents of register 17 are equal to N. In this condition, the data in slots 0 and 1 that appear in the N frames between frames with valid control slots are ignored. The default setting for register 17 is 0; control slots appear in every frame. After register 17 is programmed with a nonzero value, the first sequence has N – 1 frames with empty control slots.

Figure 6. Bit Assignment and Definition for Slot 1 Word

ADC data word

A data word occupies one time slot and is 16 bits long. The ADC data word (output on DOUT) can be any of the following:

- Data-valid flag + 15 bits of linear data
- 16 bits of linear data (no data-valid flag)
- Data-valid flag + A-law or μ -law coded PCM data
- A-law or μ -law coded PCM data (no data-valid flag)

The selection of linear, A-law, or μ -law coding is programmed in register 15, bits 6 and 7. The selection for providing the data-valid flag bit is programmed in register 13 (see the *ADC and DAC channel data* section for a detailed description of the valid and invalid data).

The structure of a data word is shown in Figures 7 and 8.

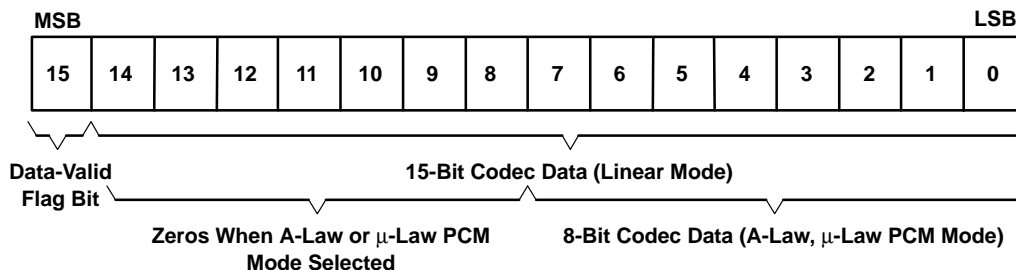

NOTE A: The MSB of the codec data is bit 14 for linear mode and bit 7 for A-law and μ -law.

Figure 7. Bit Assignment and Definition for ADC Data Word When the Data-Valid Flag Is Enabled

Figure 7 shows the ADC data word format when the data-valid flag is used. The data-valid flag is positioned in bit 15 (the MSB of the data word) and is transmitted first. The flag bit is enabled by programming register 13. Bit 14 of the data word is the MSB of the 15-bit codec data when the linear mode is selected and the data-valid flag is enabled.

When A-law or μ -law PCM coding is selected, the eight bits of the PCM data are located with the MSB in the bit-7 location and the LSB in the bit-0 location of the data word. Unused bits are zero when PCM coding is enabled.

Bit 15 always is the data-valid flag for both the PCM and linear coding when the data-valid flag is enabled. The selection of linear, A-law, or μ -law coding is programmed in register 15, bits 6 and 7.

ADC data word (continued)

Figure 8 describes the ADC data word format when the data-valid flag is disabled.

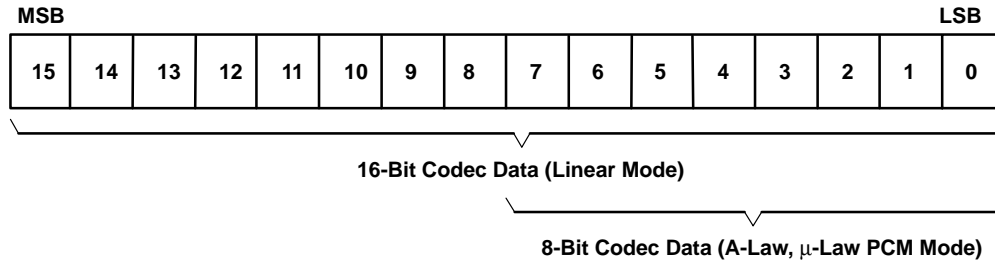

NOTE A: The MSB of the codec data is bit 15 for linear mode and bit 7 for A-law and μ -law.

Figure 8. Bit Assignment and Definition for ADC Data Word When the Data-Valid Flag Is Disabled

When the data-valid flag is disabled, 16 bits of data are presented in the linear mode, with the MSB in bit 15. When A-law or μ -law PCM coding is selected, the eight bits of the PCM data are located with the MSB in the bit-7 position and the LSB in the bit-0 position. The upper byte of the 16-bit word is ignored for PCM coding and contains zeros.

DAC data word

The DAC data word (input on DIN) can be any of the following:

- 16 bits of linear data
- A-law or μ -law coded PCM data

The structure of the DAC data word is shown in Figure 9.

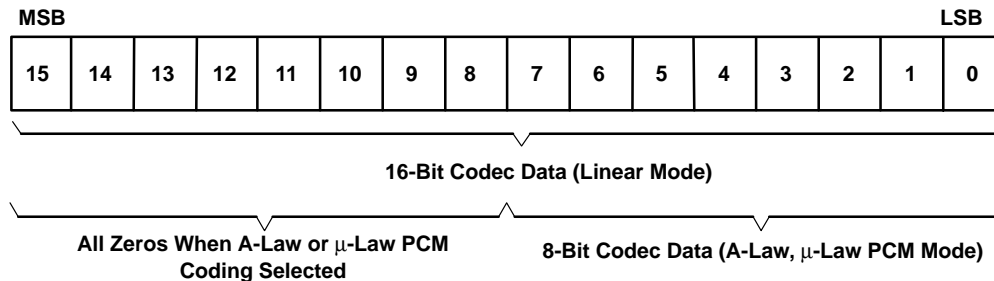

NOTE A: The MSB of the DAC data is bit 15 for linear mode and bit 7 for A-law and μ -law.

Figure 9. Bit Assignment and Definition for DAC Data Word

TLV320AIC22C

DUAL VOICE OVER INTERNET PROTOCOL (VoIP) CODEC

SPAS041B – OCTOBER 2001 – REVISED JANUARY 2003

address terminals

The AD1 and AD0 terminals are used to define the address of the codec in the I²C mode and for the serial interface (see the *register programming using the I²C bus* section for a detailed description of the I²C mode). For the serial interface, the address determines the time slot used by a certain codec. Provisions are made to support up to four TLV320AIC22Cs connected to a single DSP. With four TLV320AIC22Cs, there are eight slots used for data.

Table 5 shows how the time slots used are related to the AD1 and AD0 address lines. Codec 1 in a TLV320AIC22C communicates during the first assigned time slot, based on the AD0 and AD1 configuration, while codec 2 in the same TLV320AIC22C communicates during the second assigned time slot, based on that same AD0/AD1 configuration.

Table 5. AD0 and AD1 vs Time-Slot Assignment

TLV320AIC22C DEVICE	AD1	AD0	TIME SLOT CODEC 1	TIME SLOT CODEC 2
0	0	0	2	3
1	0	1	4	5
2	1	0	6	7
3	1	1	8	9

This address description is used to make the codec register address map unique across the codecs. This is explained further in the following paragraphs.

master/slave functionality

The TLV320AIC22C can be configured as a master or a slave. A particular codec is configured as the master by tying the M/S terminal (terminal 21) high. Tying M/S low configures the device as a slave.

This functionality can be used for connecting multiple TLV320AIC22C devices to a single McBSP port (see Figure 20). Only one device can be a master in such a system. The master device generates the FSYNC and the BCLK signals that are used by the DSP and the remaining TLV320AIC22Cs in the system. The slave devices input the FSYNC and BCLK signals generated by the master device.

The TLV320AIC22C also can be used as a stand-alone slave. In this configuration, there is no master TLV320AIC22C device providing the FSYNC and BCLK signals. FSYNC and BCLK are provided by some other device such as a DSP or ASIC.

Careful attention must be paid to the relationship between MCLK, FSYNC, and BCLK when using stand-alone slave configurations. When operating the device as a stand-alone slave, the configurations shown in Table 6 must be met.

Table 6. Slave-Mode Clock Inputs

MCLK INPUT FREQUENCY (MHz)	BCLK INPUT FREQUENCY (MHz)	FSYNC INPUT FREQUENCY (kHz)	REGISTER 12 VALUE (BITS D6–D4, DECIMAL)
24.576	2.048	8	0
24.576	4.096	16	2
32.768	2.048	8	1
32.768	4.096	16	3

All of these signals (BCLK, MCLK, and FSYNC) must be synchronous. The appropriate values for register 12, bits D6–D4, as well as the I values for codec 1 (register 2) and codec 2 (register 7), must be loaded prior to transmitting and receiving valid conversion data to obtain the desired sampling rate (see the *channel sampling rates* section for a detailed description).

zero crossing block

The zero crossing functionality (programmed in registers 15 and 16) applies whenever the user changes a preamplifier or PGA gain setting. When the user wishes to change a gain setting in a particular channel (ADC or DAC path), the changed gain takes effect when the signal level coming from the particular channel crosses a programmed threshold. The threshold can be specified in registers 15 and 16 for either channel. For example, if the user is talking on the handset and wishes to mute it, the zero crossing block checks the ADC input to see whether the input falls within the programmed range before making the mute effective internally. This is to avoid noise if a sharp change is implemented. Note, in the transmit path, the zero crossing block checks only the ADC input value. If both the handset and the microphone are in use with one ADC channel, and the user wishes to mute only the handset, the zero crossing block does not prevent noise when muting the handset. If the user mutes both the handset and the microphone, then zero crossing is evaluated properly.

On the DAC side, the zero crossing is effective in a similar manner. The DAC output is checked to see whether the value is within the programmed range. The mute then becomes effective in the driver where mute has been selected.

Deselecting mute is taken care of in the same way. If the user wants to deselect mute, the TLV320AIC22C internally checks to see if the signal level is within the programmed limit and then allows the device to leave mute. Internally, a change in gain setting becomes effective only after the signal level has reached a value near zero. If the signal does not cross the programmed zero-crossing threshold, the gain change automatically occurs after $64/f_s$ seconds.

channel sampling rates

The TLV320AIC22C can be configured to have standard sampling rates (8 kHz and 16 kHz).

The sampling rate (f_s) equals the frame synchronization rate (FSYNC).

Examples of master clock frequencies, with the derivations of the sampling rates, bit clocks, and the frame synchronization frequencies, are shown in Table 7. The default setting is for a case in which the channel sampling rate and FSYNC are at 8 kHz when an MCLK of 24.576 MHz is provided. The default setting is for register 12 to have bits D6–D4 equal to 000 and registers 1 and 7 to be left in their default configuration.

The various parameters for the sampling rates and bit shift clock rates are determined using the following equations:

BCLK = See Table 7
 FSYNC = BCLK/256
 Sample rate = MCLK/(512 × I)

Table 7. FSYNC, BCLK, and Sample Rate Derivations With Register Settings

REGISTER 12			MCLK INPUT (MHz)	FSYNC	BCLK	SAMPLE RATE	I
D6	D5	D4					
0†	0†	0†	24.576	BCLK/256 or 8 kHz	MCLK/12 or 2.048 MHz	MCLK/(512 × I) or 8 kHz	6†
0	0	1	32.768	BCLK/256 or 8 kHz	MCLK/16 or 2.048 MHz	MCLK/(512 × I) or 8 kHz	8
0	1	0	24.576	BCLK/256 or 16 kHz	MCLK/6 or 4.096 MHz	MCLK/(512 × I) or 16 kHz	3
0	1	1	32.768	MCLK/(512 × 4) or 16 kHz	MCLK/8 or 4.096 MHz	MCLK/(512 × I) or 16 kHz	4

† Default setting



TLV320AIC22C

DUAL VOICE OVER INTERNET PROTOCOL (VoIP) CODEC

SPAS041B – OCTOBER 2001 – REVISED JANUARY 2003

ADC and DAC channel data

The ADC channel produces 15 bits of 2s complement conversion data in linear mode or 7 bits of zeros and 8 bits of PCM coded data in A-law or μ -law mode, plus a data-valid flag bit which, by default, is enabled. The ADC places a 1 in the data-valid bit for all conversion data, if the valid data flag is enabled in register 13.

The DAC uses 16 bits of 2s-complement data or 8 bits of zeros, followed by 8 bits of PCM data as input. No data-valid flag is required for the DAC data.

register programming

The TLV320AIC22C contains 18 registers that are used to configure the device for the desired operation. Register programming is accomplished in two different ways:

- Serial interface (time slots 0 and 1)
- I²C bus

The I²C/SPI terminal is used to select either interface for programming the device.

register programming using the serial interface

To program the control registers using the serial interface, I²C/SPI should be tied to logic 0. The frame format and control word description are discussed previously in *serial interface* section.

Time slots 0 and 1 are used for codec register programming and are configured as follows:

- Slot 0 – Read/write, physical address of codec register

This is the register address appended to the codec address derived from terminals AD0 and AD1.

- Slot 1 – Value to be written in the codec register for a write operation

For a read operation, the DIN slot 1 is zero stuffed. Depending on the register to be read, the codec puts the register contents on the slot 1 of DOUT in the same frame.

The following are examples of programming a TLV320AIC22C whose device address is set to 0 (AD0 = AD1 = 0).

example 1: write operation ($\overline{R}/W = 1$)

Programming control register 15 of a device with address 0x00h, with the data set to 0x23h, results in the following data being driven on the DIN terminal for time slots 0 and 1:

Slot 0: 1 00 0000 1111 00000
 Slot 1: 0010 0011 0000 0000

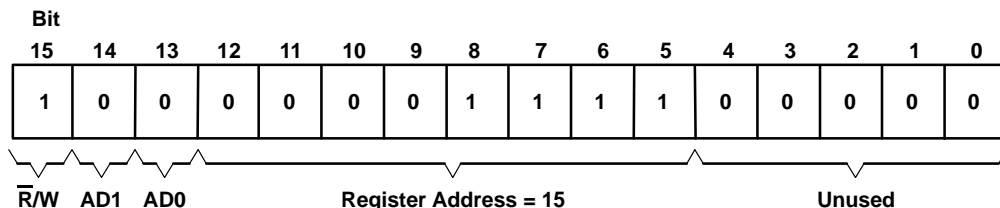
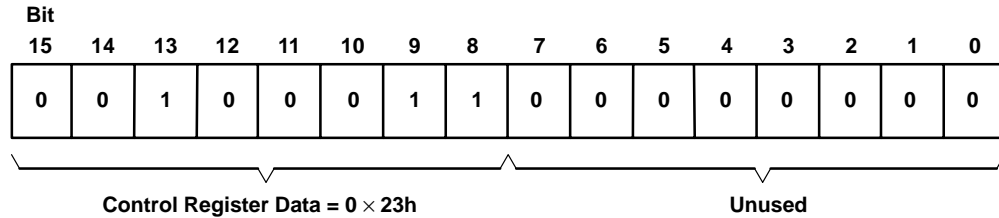

Figure 10. DIN Data Stream for Programming Example 1, Slot 0



I²C-bus conditions

The data on the line must be changed during the low period of the clock signal. There is one clock pulse per bit data and each data transfer is initiated with a start condition and terminated with a stop condition. The host device determines the number of data bytes transferred between the start and stop conditions. When addressed, the TLV320AIC22C generates an acknowledge after the reception of each byte. The host device (microprocessor or DSP) must generate an extra clock pulse, which is associated with this acknowledge bit.

The TLV320AIC22C must pull the SDA line down during the acknowledge clock pulse, so that the SDA line is stable low during the high period of the acknowledge-related clock pulse. Setup and hold times must be taken into account. During reads, a host device must signal an end of data to the slave by not generating an acknowledge bit on the last byte that has been clocked out of the slave. In this case, the slave (TLV320AIC22C) must leave the data line high to enable the host device to generate the stop condition.

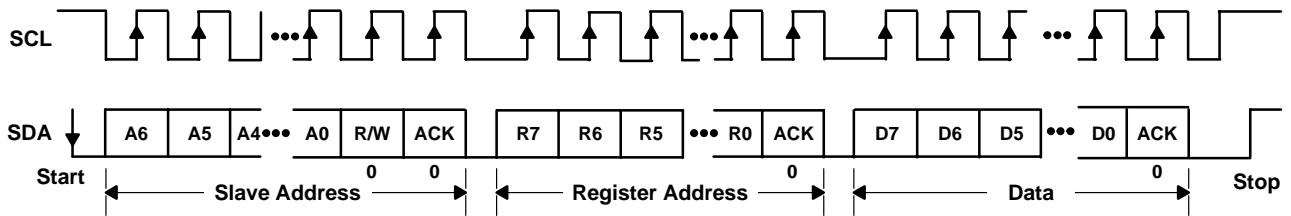

Figure 15. I²C-Bus Write to TLV320AIC22C

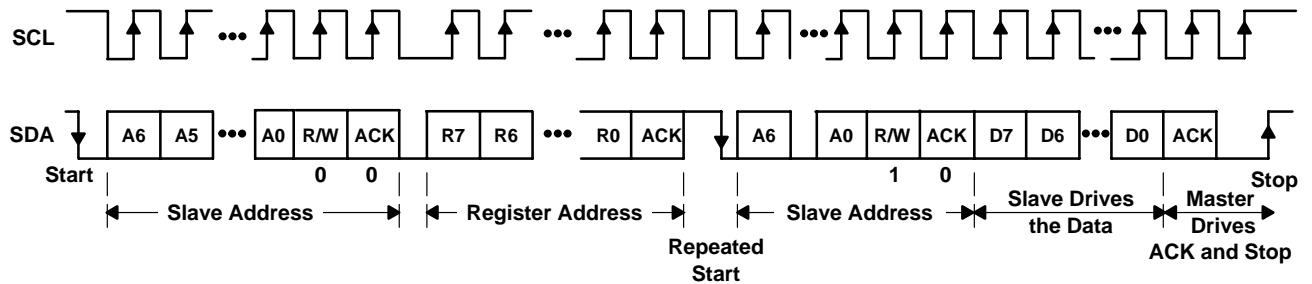
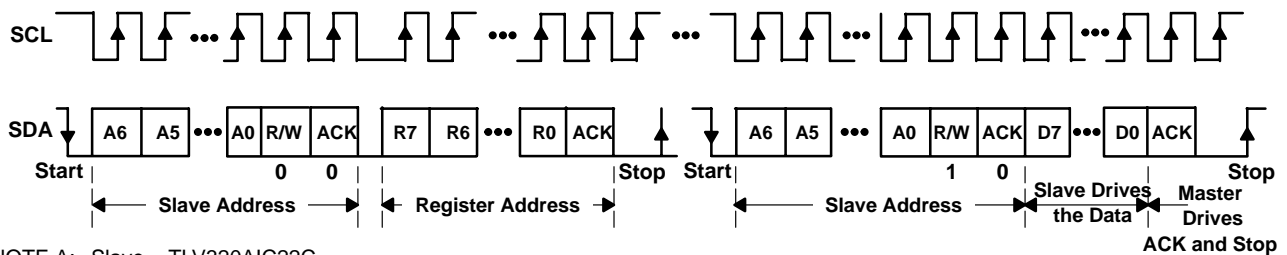

Figure 16. I²C Read From TLV320AIC22C (Protocol A)



NOTE A: Slave = TLV320AIC22C

Figure 17. I²C Read From TLV320AIC22C (Protocol B)

TLV320AIC22C

DUAL VOICE OVER INTERNET PROTOCOL (VoIP) CODEC

SPAS041B – OCTOBER 2001 – REVISED JANUARY 2003

PGA and preamp gain setting

The ability to control when ADC and DAC PGA and preamp gain settings take effect is provided. Programming bit 2 in register 21 controls this feature.

When bit 2 in register 21 is set to 0, the PGA and preamp gain settings take effect after the desired gain is programmed in register 3, 4, 8, 9, or 11.

To control when a gain change takes place, register 21, bit 2 must be set to 1. No gain change made in registers 3, 4, 8, 9, or 11 takes place after the register is programmed. All previously recognized settings remain in place as long as register 21, bit 2 is set to 1. The gain change is not made until after register 21, bit 2 is set to 0.

The timing of when the new ADC PGA and preamp gains actually are initiated is a fixed delay (only when the zero crossing feature is not active). The sequence is:

- Register 21, bit D2 is set to 1.
- New ADC or DAC PGA or preamp gain data is written to registers 3, 4, 8, 9, or 11.
- Register 21, bit D2 is set to 0.
- The new gains are applied to the internal circuitry within a maximum of one sample frequency time period (125 μ s for an 8-kHz sample rate or 62.5 μ s for a 16-kHz sample rate).

This feature allows the user to apply preamp and PGA gains simultaneously. This avoids any delays incurred as a result of the PGA and preamp gains being spread across multiple registers.



POST OFFICE BOX 655303 • DALLAS, TEXAS 75265

register functional summary

The following features are register programmable:

- Software reset
- Software power down
- Selection of digital loopback for both channels
- Selection of analog loopback for both channels
- Selection of I values for both channels
- Analog crosspoint control
 - Analog input for codec 1, selectable from five possible inputs
 - Analog input for codec 2, selectable from five possible inputs
 - Analog output for codec 1, selectable from four possible outputs
 - Analog output for codec 2, selectable from four possible outputs
- Handset input amplifier gain select (mute, 0/14/23 dB)
- Headset input amplifier gain select (mute, 0/14/23 dB)
- Handset and headset echo gain select (mute, –12 dB to –24 dB in steps of 2 dB)
- Microphone input amplifier gain select (mute, 42 dB, 32 dB, 20 dB, or 0 dB)
- Gain selection for the ADC input PGA (mute, 12 dB to –36 dB in steps of 1.5 dB) and DAC output PGA (mute, 12 dB to –36 dB in steps of 1.5 dB) for both channels
- Linear/A-law/ μ -law mode select for both codecs
- Independent power down for drivers
- 4-bit DAC voltage control
- HPF bypass for both channels
- Analog filter pole select (16 kHz, 21.3 kHz, 32 kHz, 64 kHz)
- Zero crossing enable and threshold
- Number of frames after which control information is to be sent

register map

Registers 1–5 and 15 are used to control codec 1.

Registers 6–10 and 16 are used to control codec 2.

Registers 11–14 and 17 are used to configure the device inputs, outputs, and clocking.

Register 21 – Device ID and preamp control

TLV320AIC22C

DUAL VOICE OVER INTERNET PROTOCOL (VoIP) CODEC

SPAS041B – OCTOBER 2001 – REVISED JANUARY 2003

control register 1 (for codec 1)

register address = 00000001

D7	D6	D5	D4	D3	D2	D1	D0	DESCRIPTION
X	X	X	X					Reserved; this register must remain in the default setting.
				X	X	X	X	Reserved; this register must remain in the default setting.

Default value: 0101 0000 (D = 6 and N = 0)

control register 2 (for codec 1)

register address = 00000010

D7	D6	D5	D4	D3	D2	D1	D0	DESCRIPTION
X	X	X	X					Binary number representing the I register for codec 1 (loaded as I-1)
				1				Analog loopback asserted
				0				Analog loopback not asserted
					1			Digital loopback asserted
					0			Digital loopback not asserted
						1		Codec 1 power down asserted
						0		Codec 1 power down not asserted
							1	Software reset (registers 1-5 and 15 are reset to default setting)
							0	Software reset not asserted

Default value: 0101 0000 (I = 6)

TLV320AIC22C

DUAL VOICE OVER INTERNET PROTOCOL (VoIP) CODEC

SPAS041B – OCTOBER 2001 – REVISED JANUARY 2003

control register 3 (for codec 1)

register address = 00000011

D7	D6	D5	D4	D3	D2	D1	D0	DESCRIPTION
X								ADC codec overflow indicator
	1	1	0	0	0	0		Codec 1 ADC input PGA gain = mute
	1	0	0	0	0	1		Codec 1 ADC input PGA gain = 12 dB
	1	0	0	0	0	0		Codec 1 ADC input PGA gain = 10.5 dB
	0	1	1	1	1	1		Codec 1 ADC input PGA gain = 9 dB
	0	1	1	1	1	0		Codec 1 ADC input PGA gain = 7.5 dB
	0	1	1	1	0	1		Codec 1 ADC input PGA gain = 6 dB
	0	1	1	1	0	0		Codec 1 ADC input PGA gain = 4.5 dB
	0	1	1	0	1	1		Codec 1 ADC input PGA gain = 3 dB
	0	1	1	0	1	0		Codec 1 ADC input PGA gain = 1.5 dB
	0	1	1	0	0	1		Codec 1 ADC input PGA gain = 0 dB
	0	1	1	0	0	0		Codec 1 ADC input PGA gain = -1.5 dB
	0	1	0	1	1	1		Codec 1 ADC input PGA gain = -3 dB
	0	1	0	1	1	0		Codec 1 ADC input PGA gain = -4.5 dB
	0	1	0	1	0	1		Codec 1 ADC input PGA gain = -6 dB
	0	1	0	1	0	0		Codec 1 ADC input PGA gain = -7.5 dB
	0	1	0	0	1	1		Codec 1 ADC input PGA gain = -9 dB
	0	1	0	0	1	0		Codec 1 ADC input PGA gain = -10.5 dB
	0	1	0	0	0	1		Codec 1 ADC input PGA gain = -12 dB
	0	1	0	0	0	0		Codec 1 ADC input PGA gain = -13.5 dB
	0	0	1	1	1	1		Codec 1 ADC input PGA gain = -15 dB
	0	0	1	1	1	0		Codec 1 ADC input PGA gain = -16.5 dB
	0	0	1	1	0	1		Codec 1 ADC input PGA gain = -18 dB
	0	0	1	1	0	0		Codec 1 ADC input PGA gain = -19.5 dB
	0	0	1	0	1	1		Codec 1 ADC input PGA gain = -21 dB
	0	0	1	0	1	0		Codec 1 ADC input PGA gain = -22.5 dB
	0	0	1	0	0	1		Codec 1 ADC input PGA gain = -24 dB
	0	0	1	0	0	0		Codec 1 ADC input PGA gain = -25.5 dB
	0	0	0	1	1	1		Codec 1 ADC input PGA gain = -27 dB
	0	0	0	1	1	0		Codec 1 ADC input PGA gain = -28.5 dB
	0	0	0	1	0	1		Codec 1 ADC input PGA gain = -30 dB
	0	0	0	1	0	0		Codec 1 ADC input PGA gain = -31.5 dB
	0	0	0	0	1	1		Codec 1 ADC input PGA gain = -33 dB
	0	0	0	0	1	0		Codec 1 ADC input PGA gain = -34.5 dB
	0	0	0	0	0	1		Codec 1 ADC input PGA gain = -36 dB
	0	0	0	0	0	0		Codec 1 ADC input PGA gain = 0 dB
							1	Line output (LNOUT) selected for analog output
							0	Line output (LNOUT) not selected for analog output

Default value: x0000000



TLV320AIC22C DUAL VOICE OVER INTERNET PROTOCOL (VoIP) CODEC

SPAS041B – OCTOBER 2001 – REVISED JANUARY 2003

control register 4 (for codec 1)

register address = 00000100

D7	D6	D5	D4	D3	D2	D1	D0	DESCRIPTION
X	X							Not used
		1	1	0	0	0	0	Codec 1 DAC output PGA gain = mute
		1	0	0	0	0	1	Codec 1 DAC output PGA gain = 12 dB
		1	0	0	0	0	0	Codec 1 DAC output PGA gain = 10.5 dB
		0	1	1	1	1	1	Codec 1 DAC output PGA gain = 9 dB
		0	1	1	1	1	0	Codec 1 DAC output PGA gain = 7.5 dB
		0	1	1	1	0	1	Codec 1 DAC output PGA gain = 6 dB
		0	1	1	1	0	0	Codec 1 DAC output PGA gain = 4.5 dB
		0	1	1	0	1	1	Codec 1 DAC output PGA gain = 3 dB
		0	1	1	0	1	0	Codec 1 DAC output PGA gain = 1.5 dB
		0	1	1	0	0	1	Codec 1 DAC output PGA gain = 0 dB
		0	1	1	0	0	0	Codec 1 DAC output PGA gain = -1.5 dB
		0	1	0	1	1	1	Codec 1 DAC output PGA gain = -3 dB
		0	1	0	1	1	0	Codec 1 DAC output PGA gain = -4.5 dB
		0	1	0	1	0	1	Codec 1 DAC output PGA gain = -6 dB
		0	1	0	1	0	0	Codec 1 DAC output PGA gain = -7.5 dB
		0	1	0	0	1	1	Codec 1 DAC output PGA gain = -9 dB
		0	1	0	0	1	0	Codec 1 DAC output PGA gain = -10.5 dB
		0	1	0	0	0	1	Codec 1 DAC output PGA gain = -12 dB
		0	1	0	0	0	0	Codec 1 DAC output PGA gain = -13.5 dB
		0	0	1	1	1	1	Codec 1 DAC output PGA gain = -15 dB
		0	0	1	1	1	0	Codec 1 DAC output PGA gain = -16.5 dB
		0	0	1	1	0	1	Codec 1 DAC output PGA gain = -18 dB
		0	0	1	1	0	0	Codec 1 DAC output PGA gain = -19.5 dB
		0	0	1	0	1	1	Codec 1 DAC output PGA gain = -21 dB
		0	0	1	0	1	0	Codec 1 DAC output PGA gain = -22.5 dB
		0	0	1	0	0	1	Codec 1 DAC output PGA gain = -24 dB
		0	0	1	0	0	0	Codec 1 DAC output PGA gain = -25.5 dB
		0	0	0	1	1	1	Codec 1 DAC output PGA gain = -27 dB
		0	0	0	1	1	0	Codec 1 DAC output PGA gain = -28.5 dB
		0	0	0	1	0	1	Codec 1 DAC output PGA gain = -30 dB
		0	0	0	1	0	0	Codec 1 DAC output PGA gain = -31.5 dB
		0	0	0	0	1	1	Codec 1 DAC output PGA gain = -33 dB
		0	0	0	0	1	0	Codec 1 DAC output PGA gain = -34.5 dB
		0	0	0	0	0	1	Codec 1 DAC output PGA gain = -36 dB
		0	0	0	0	0	0	Codec 1 DAC output PGA gain = 0 dB

Default value: xx000000



TLV320AIC22C DUAL VOICE OVER INTERNET PROTOCOL (VoIP) CODEC

SPAS041B – OCTOBER 2001 – REVISED JANUARY 2003

control register 5 (for codec 1)

register address = 00000101

D7	D6	D5	D4	D3	D2	D1	D0	DESCRIPTION
1								Handset input (HSIN) selected for analog input
0								Handset input (HSIN) not selected for analog input
	1							Headset input (HDIN) selected for analog input
	0							Headset input (HDIN) not selected for analog input
		1						Microphone input (MCIN) selected for analog input
		0						Microphone input (MCIN) not selected for analog input
			1					Line input (LNIN) selected for analog input
			0					Line input (LNIN) not selected for analog input
				1				CallerID amplifier input (CIIN) selected for analog input
				0				CallerID amplifier input (CIIN) not selected for analog input
					1			Handset output (HSOUT) selected for analog output
					0			Handset output (HSOUT) not selected for analog output
						1		Headset output (HDOOUT) selected for analog output
						0		Headset output (HDOOUT) not selected for analog output
							1	Speaker output (SPOUT) selected for analog output
							0	Speaker output (SPOUT) not selected for analog output

Default value: 1000 0100

control register 6 (for codec 2)

register address = 00000110

D7	D6	D5	D4	D3	D2	D1	D0	DESCRIPTION
X	X	X	X					Reserved; this register must remain in the default setting.
				X	X	X	X	Reserved; this register must remain in the default setting.

Default value: 0101 0000 (D = 6 and N = 0)

control register 7 (for codec 2)

register address = 00000111

D7	D6	D5	D4	D3	D2	D1	D0	DESCRIPTION
X	X	X	X					Binary number representing the I register for codec 2 (loaded as I – 1)
				1				Analog loopback asserted
				0				Analog loopback not asserted
					1			Digital loopback asserted
					0			Digital loopback not asserted
						1		Codec 2 power down asserted
						0		Codec 2 power down not asserted
							1	Software reset (registers 6–14, 16, and 17 are reset to their default settings)
							0	Software reset not asserted

Default value: 0101 0000 (I = 6)



TLV320AIC22C

DUAL VOICE OVER INTERNET PROTOCOL (VoIP) CODEC

SPAS041B – OCTOBER 2001 – REVISED JANUARY 2003

control register 8 (for codec 2)

register address = 00001000

D7	D6	D5	D4	D3	D2	D1	D0	DESCRIPTION
X								ADC codec overflow indicator
	1	1	0	0	0	0		Codec 2 ADC input PGA gain = mute
	1	0	0	0	0	1		Codec 2 ADC input PGA gain = 12 dB
	1	0	0	0	0	0		Codec 2 ADC input PGA gain = 10.5 dB
	0	1	1	1	1	1		Codec 2 ADC input PGA gain = 9 dB
	0	1	1	1	1	0		Codec 2 ADC input PGA gain = 7.5 dB
	0	1	1	1	0	1		Codec 2 ADC input PGA gain = 6 dB
	0	1	1	1	0	0		Codec 2 ADC input PGA gain = 4.5 dB
	0	1	1	0	1	1		Codec 2 ADC input PGA gain = 3 dB
	0	1	1	0	1	0		Codec 2 ADC input PGA gain = 1.5 dB
	0	1	1	0	0	1		Codec 2 ADC input PGA gain = 0 dB
	0	1	1	0	0	0		Codec 2 ADC input PGA gain = -1.5 dB
	0	1	0	1	1	1		Codec 2 ADC input PGA gain = -3 dB
	0	1	0	1	1	0		Codec 2 ADC input PGA gain = -4.5 dB
	0	1	0	1	0	1		Codec 2 ADC input PGA gain = -6 dB
	0	1	0	1	0	0		Codec 2 ADC input PGA gain = -7.5 dB
	0	1	0	0	1	1		Codec 2 ADC input PGA gain = -9 dB
	0	1	0	0	1	0		Codec 2 ADC input PGA gain = -10.5 dB
	0	1	0	0	0	1		Codec 2 ADC input PGA gain = -12 dB
	0	1	0	0	0	0		Codec 2 ADC input PGA gain = -13.5 dB
	0	0	1	1	1	1		Codec 2 ADC input PGA gain = -15 dB
	0	0	1	1	1	0		Codec 2 ADC input PGA gain = -16.5 dB
	0	0	1	1	0	1		Codec 2 ADC input PGA gain = -18 dB
	0	0	1	1	0	0		Codec 2 ADC input PGA gain = -19.5 dB
	0	0	1	0	1	1		Codec 2 ADC input PGA gain = -21 dB
	0	0	1	0	1	0		Codec 2 ADC input PGA gain = -22.5 dB
	0	0	1	0	0	1		Codec 2 ADC input PGA gain = -24 dB
	0	0	1	0	0	0		Codec 2 ADC input PGA gain = -25.5 dB
	0	0	0	1	1	1		Codec 2 ADC input PGA gain = -27 dB
	0	0	0	1	1	0		Codec 2 ADC input PGA gain = -28.5 dB
	0	0	0	1	0	1		Codec 2 ADC input PGA gain = -30 dB
	0	0	0	1	0	0		Codec 2 ADC input PGA gain = -31.5 dB
	0	0	0	0	1	1		Codec 2 ADC input PGA gain = -33 dB
	0	0	0	0	1	0		Codec 2 ADC input PGA gain = -34.5 dB
	0	0	0	0	0	1		Codec 2 ADC input PGA gain = -36 dB
	0	0	0	0	0	0		Codec 2 ADC input PGA gain = 0 dB
							1	Line output (LNOUT) selected for analog output
							0	Line output (LNOUT) not selected for analog output

Default value: x0000001



TLV320AIC22C

DUAL VOICE OVER INTERNET PROTOCOL (VoIP) CODEC

SPAS041B – OCTOBER 2001 – REVISED JANUARY 2003

control register 9 (for codec 2)

register address = 00001001

D7	D6	D5	D4	D3	D2	D1	D0	DESCRIPTION
X	X							Don't care
		1	1	0	0	0	0	Codec 2 DAC output PGA gain = mute
		1	0	0	0	0	1	Codec 2 DAC output PGA gain = 12 dB
		1	0	0	0	0	0	Codec 2 DAC output PGA gain = 10.5 dB
		0	1	1	1	1	1	Codec 2 DAC output PGA gain = 9 dB
		0	1	1	1	1	0	Codec 2 DAC output PGA gain = 7.5 dB
		0	1	1	1	0	1	Codec 2 DAC output PGA gain = 6 dB
		0	1	1	1	0	0	Codec 2 DAC output PGA gain = 4.5 dB
		0	1	1	0	1	1	Codec 2 DAC output PGA gain = 3 dB
		0	1	1	0	1	0	Codec 2 DAC output PGA gain = 1.5 dB
		0	1	1	0	0	1	Codec 2 DAC output PGA gain = 0 dB
		0	1	1	0	0	0	Codec 2 DAC output PGA gain = -1.5 dB
		0	1	0	1	1	1	Codec 2 DAC output PGA gain = -3 dB
		0	1	0	1	1	0	Codec 2 DAC output PGA gain = -4.5 dB
		0	1	0	1	0	1	Codec 2 DAC output PGA gain = -6 dB
		0	1	0	1	0	0	Codec 2 DAC output PGA gain = -7.5 dB
		0	1	0	0	1	1	Codec 2 DAC output PGA gain = -9 dB
		0	1	0	0	1	0	Codec 2 DAC output PGA gain = -10.5 dB
		0	1	0	0	0	1	Codec 2 DAC output PGA gain = -12 dB
		0	1	0	0	0	0	Codec 2 DAC output PGA gain = -13.5 dB
		0	0	1	1	1	1	Codec 2 DAC output PGA gain = -15 dB
		0	0	1	1	1	0	Codec 2 DAC output PGA gain = -16.5 dB
		0	0	1	1	0	1	Codec 2 DAC output PGA gain = -18 dB
		0	0	1	1	0	0	Codec 2 DAC output PGA gain = -19.5 dB
		0	0	1	0	1	1	Codec 2 DAC output PGA gain = -21 dB
		0	0	1	0	1	0	Codec 2 DAC output PGA gain = -22.5 dB
		0	0	1	0	0	1	Codec 2 DAC output PGA gain = -24 dB
		0	0	1	0	0	0	Codec 2 DAC output PGA gain = -25.5 dB
		0	0	0	1	1	1	Codec 2 DAC output PGA gain = -27 dB
		0	0	0	1	1	0	Codec 2 DAC output PGA gain = -28.5 dB
		0	0	0	1	0	1	Codec 2 DAC output PGA gain = -30 dB
		0	0	0	1	0	0	Codec 2 DAC output PGA gain = -31.5 dB
		0	0	0	0	1	1	Codec 2 DAC output PGA gain = -33 dB
		0	0	0	0	1	0	Codec 2 DAC output PGA gain = -34.5 dB
		0	0	0	0	0	1	Codec 2 DAC output PGA gain = -36 dB
		0	0	0	0	0	0	Codec 2 DAC output PGA gain = 0 dB

Default value: xx000000



TLV320AIC22C

DUAL VOICE OVER INTERNET PROTOCOL (VoIP) CODEC

SPAS041B – OCTOBER 2001 – REVISED JANUARY 2003

control register 10 (for codec 2)

register address = 00001010

D7	D6	D5	D4	D3	D2	D1	D0	DESCRIPTION
1								Handset input (HSIN) selected for analog input
0								Handset input (HSIN) not selected for analog input
	1							Headset input (HDIN) selected for analog input
	0							Headset input (HDIN) not selected for analog input
		1						Microphone input (MCIN) selected for analog input
		0						Microphone input (MCIN) not selected for analog input
			1					Line input (LNIN) selected for analog input
			0					Line input (LNIN) not selected for analog input
				1				Caller ID amplifier input (CIIN) selected for analog input
				0				Caller ID amplifier input (CIIN) not selected for analog input
					1			Handset output (HSOUT) selected for analog output
					0			Handset output (HSOUT) not selected for analog output
						1		Headset output (HDOOUT) selected for analog output
						0		Headset output (HDOOUT) not selected for analog output
							1	Speaker output (SPOUT) selected for analog output
							0	Speaker output (SPOUT) not selected for analog output

Default value: 0001 0000

control register 11

register address = 00001011

D7	D6	D5	D4	D3	D2	D1	D0	DESCRIPTION
0	0							Handset input amplifier gain = 14 dB
0	1							Handset input amplifier gain = 23 dB
1	0							Handset input amplifier gain = mute
1	1							Handset input amplifier gain = 0 dB
		0	0					Headset input amplifier gain = 14 dB
		0	1					Headset input amplifier gain = 23 dB
		1	0					Headset input amplifier gain = mute
		1	1					Headset input amplifier gain = 0 dB
				0	0	0		Microphone input amplifier gain = 32 dB
				0	0	1		Microphone input amplifier gain = 20 dB
				0	1	0		Microphone input amplifier gain = 42 dB
				0	1	1		Microphone input amplifier gain = 0 dB
				1	1	1		Microphone input amplifier gain = mute
							1	Speaker output powered down (mute)
							0	Speaker output enabled

Default value: 0000 0001



TLV320AIC22C

DUAL VOICE OVER INTERNET PROTOCOL (VoIP) CODEC

SPAS041B – OCTOBER 2001 – REVISED JANUARY 2003

control register 12

register address = 00001100

D7	D6	D5	D4	D3	D2	D1	D0	DESCRIPTION
X								Don't care
	0	0	0					FSYNC is 8 kHz for MCLK = 24.576 MHz
	0	0	1					FSYNC is 8 kHz for MCLK = 32.768 MHz
	0	1	0					FSYNC is 16 kHz for MCLK = 24.576 MHz
	0	1	1					FSYNC is 16 kHz for MCLK = 32.768 MHz
	1	0	0					Reserved
	1	0	1					FSYNC is 64 kHz for MCLK = 32.768 MHz and 48 kHz for MCLK = 24.576 MHz
	1	1	0					Reserved
	1	1	1					Reserved
				X	X	X	X	LCD DAC output voltage = $1.5 + (3/16) \times (\text{decimal value})$

Default value: x000 0000

control register 13

register address = 00001101

D7	D6	D5	D4	D3	D2	D1	D0	DESCRIPTION
1								Handset output powered down (mute)
0								Handset output enabled
	X							Don't care
		X						Don't care
			0	0	0			Handset echo gain = -12 dB
			0	0	1			Handset echo gain = -14 dB
			0	1	0			Handset echo gain = -16 dB
			0	1	1			Handset echo gain = -18 dB
			1	0	0			Handset echo gain = -20 dB
			1	0	1			Handset echo gain = -22 dB
			1	1	0			Handset echo gain = -24 dB
			1	1	1			Handset echo gain = mute
						1		Data-valid flag is disabled.
						0		Data-valid flag is enabled. The fifteenth bit (MSB) of the 16-bit data word transmitted from the TLV320AIC22C indicates that the data is valid (bit 15 = 1) or invalid (bit 15 = 0).
							1	Version ID bit. Device is a TLV320AIC22C.
							0	Version ID bit. Device is a TLV320AIC22C (see Note 14).

NOTE 14: Bit 0 is not a read-only bit in the older TLV320AIC22 devices. Therefore, the version ID bit should be read immediately after power is applied or the device is reset. The version ID bit is a read-only bit in the TLV320AIC22C.

Default value: 0xx0 0001



TLV320AIC22C

DUAL VOICE OVER INTERNET PROTOCOL (VoIP) CODEC

SPAS041B – OCTOBER 2001 – REVISED JANUARY 2003

control register 14

register address = 00001110

D7	D6	D5	D4	D3	D2	D1	D0	DESCRIPTION
1								Headset output powered down (mute)
0								Headset output enabled
	0	0						Analog pole-select for line amplifier. Filter pole at 64 kHz.
	0	1						Analog pole-select for line amplifier. Filter pole at 32 kHz.
	1	0						Analog pole-select for line amplifier. Filter pole at 21.3 kHz.
	1	1						Analog pole-select for line amplifier. Filter pole at 16 kHz.
			0	0	0			Headset echo gain = -12 dB
			0	0	1			Headset echo gain = -14 dB
			0	1	0			Headset echo gain = -16 dB
			0	1	1			Headset echo gain = -18 dB
			1	0	0			Headset echo gain = -20 dB
			1	0	1			Headset echo gain = -22 dB
			1	1	0			Headset echo gain = -24 dB
			1	1	1			Headset echo gain = mute
						1		Analog master power down active. Entire analog section is powered down.
						0		Analog master power down not active
							1	Line output, line input amplifiers powered down; VCOM is floating.
							0	Line output, line input, and VCOM are enabled.

Default value: 0000 0000

control register 15 (for codec 1)

register address = 00001111

D7	D6	D5	D4	D3	D2	D1	D0	DESCRIPTION
0	X							Linear mode selected
1	0							A-law mode selected
1	1							μ-law mode selected
		1						Zero crossing disabled for ADC
		0						Zero crossing enabled for ADC
			1					Zero crossing disabled for DAC
			0					Zero crossing enabled for DAC
				1				ADC channel HPF bypassed
				0				ADC channel HPF not bypassed
					1			Zero crossing disabled
					0			Zero crossing enabled
						0	0	Number of LSBs used to determine the zero crossing threshold = 6
						0	1	Number of LSBs used to determine the zero crossing threshold = 4
						1	0	Number of LSBs used to determine the zero crossing threshold = 8
						1	1	Number of LSBs used to determine the zero crossing threshold = 10

Default value: 00xx 0000



control register 16 (for codec 2)

register address = 00010000

D7	D6	D5	D4	D3	D2	D1	D0	DESCRIPTION
0	X							Linear mode selected
1	0							A-law mode selected
1	1							μ-law mode selected
		1						Zero crossing disabled for ADC
		0						Zero crossing enabled for ADC
			1					Zero crossing disabled for DAC
			0					Zero crossing enabled for DAC
				1				ADC channel HPF bypassed
				0				ADC channel HPF not bypassed
					1			Zero crossing disabled
					0			Zero crossing enabled
						0	0	Number of LSBs used to determine the zero crossing threshold = 6
						0	1	Number of LSBs used to determine the zero crossing threshold = 4
						1	0	Number of LSBs used to determine the zero crossing threshold = 8
						1	1	Number of LSBs used to determine the zero crossing threshold = 10

Default value: 00xx 0000

control register 17

register address = 00010001

D7	D6	D5	D4	D3	D2	D1	D0	DESCRIPTION
X	X	X	X	X	X	X	X	Number of frames that do not contain control information present between frames containing control information. Loading zero makes control information present in every frame.

Default value: 0000 0000

control register 18

register address = 0001 0010

D7	D6	D5	D4	D3	D2	D1	D0	DESCRIPTION
0	0	0	0	0	0	0	0	Reserved

Default value: 0000 0000

control register 19

register address = 0001 0011

D7	D6	D5	D4	D3	D2	D1	D0	DESCRIPTION
0	0	0	0	0	0	0	0	Reserved

Default value: 0000 0000

TLV320AIC22C

DUAL VOICE OVER INTERNET PROTOCOL (VoIP) CODEC

SPAS041B – OCTOBER 2001 – REVISED JANUARY 2003

control register 20

register address = 0001 0100

D7	D6	D5	D4	D3	D2	D1	D0	DESCRIPTION
0	0	0	0	0	0	0	0	Reserved

Default value: 0000 0000

control register 21

register address = 0001 0101

D7	D6	D5	D4	D3	D2	D1	D0	DESCRIPTION
V	V	V	V					AIC22C version. Binary representation of the version of the AIC22C. 0000 is not a valid combination.
				X				Reserved
					1			PGA/preamplification update control. If there have been any changes to the PGA or preamp gain settings in register 3, 4, 8, 9, or 11 after this bit is set to a 1, then the new values are not immediately read by the device. The previous values remain active until this bit is set to 0.
					0			PGA/preamplification update control. The PGA and preamp gain settings in registers 3, 4, 8, 9, and 11 are read by the device immediately after being written.
						X	X	Reserved

Default value: 0001 1000



APPLICATION INFORMATION

TLV320AIC22C-to-DSP interface

The TLV320AIC22C interfaces gluelessly to the McBSP port of a C54x or C6x TI DSP. Figure 18 shows a single TLV320AIC22C connected to a C54x or C6x TI DSP. Figure 19 shows multiple TLV320AIC22Cs connected to a single McBSP port (master/slave functionality).

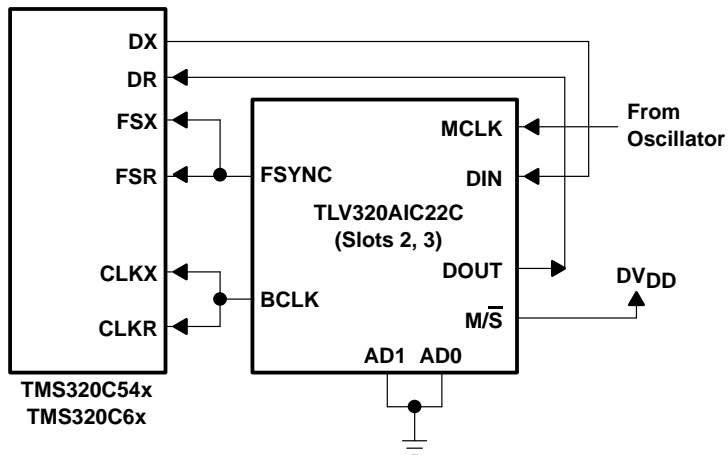

Figure 18. TLV320AIC22Cs Interface to McBSP Port of C54x or C6x DSP

TLV320AIC22C DUAL VOICE OVER INTERNET PROTOCOL (VoIP) CODEC

SPAS041B – OCTOBER 2001 – REVISED JANUARY 2003

APPLICATION INFORMATION

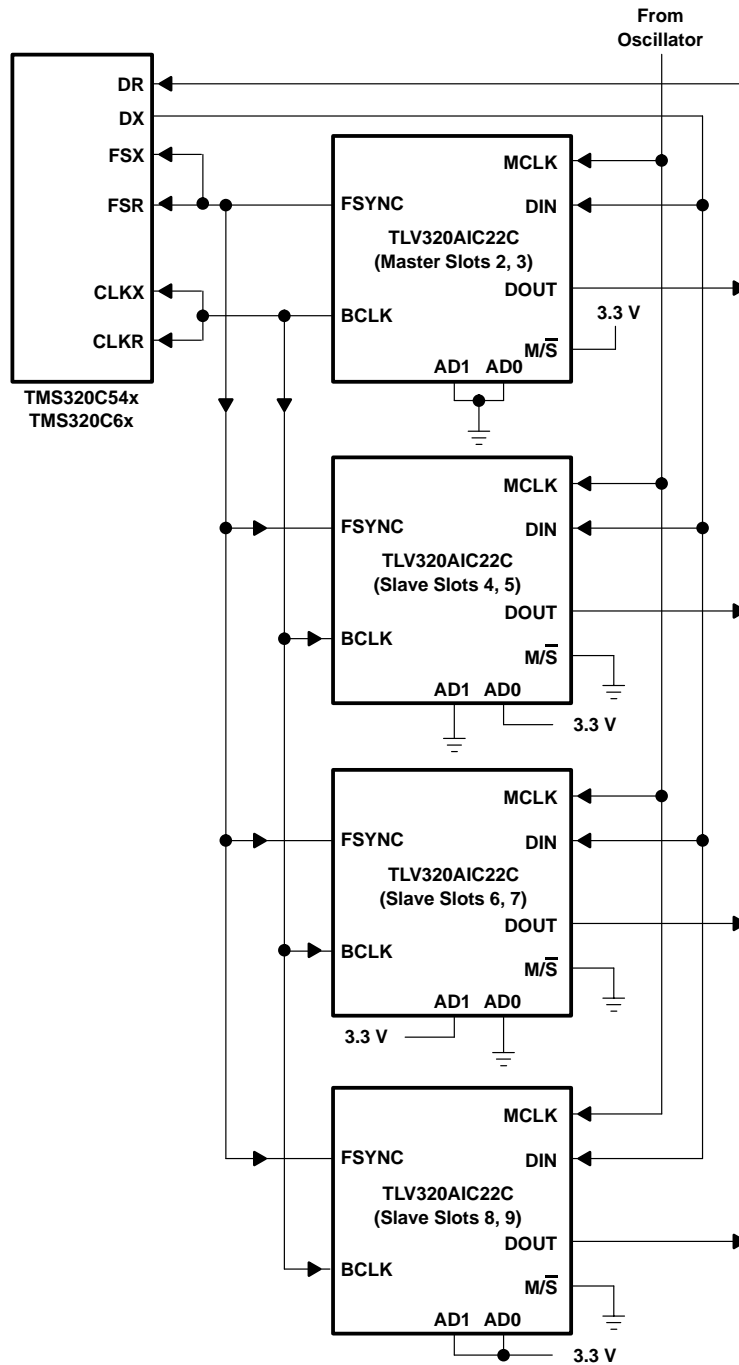

Figure 19. Four TLV320AIC22Cs Cascaded to Provide Eight Channels

APPLICATION INFORMATION

hybrid-circuit external connections

The TLV320AIC22C, connected to the telephone line using the LNIN and LNOUT hybrid circuit, is shown in Figure 20.

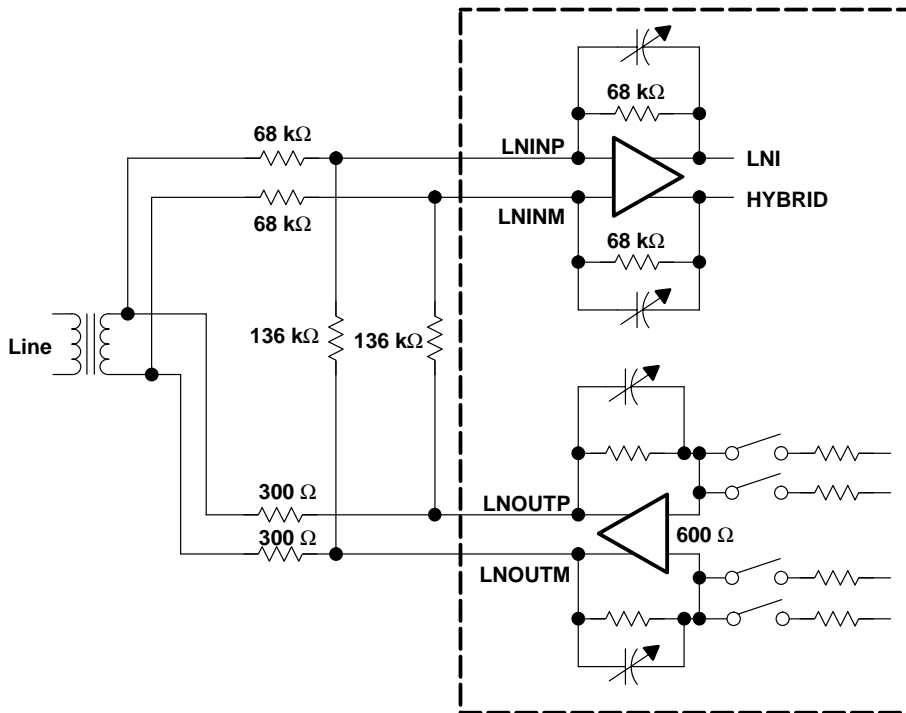

Figure 20. Hybrid-Circuit External Connections

TLV320AIC22C DUAL VOICE OVER INTERNET PROTOCOL (VoIP) CODEC

SPAS041B – OCTOBER 2001 – REVISED JANUARY 2003

APPLICATION INFORMATION

microphone, handset, and headset external connections

The microphone, handset, and headset external connections are shown in Figure 21. The suggested discrete components, with their values, also are included.

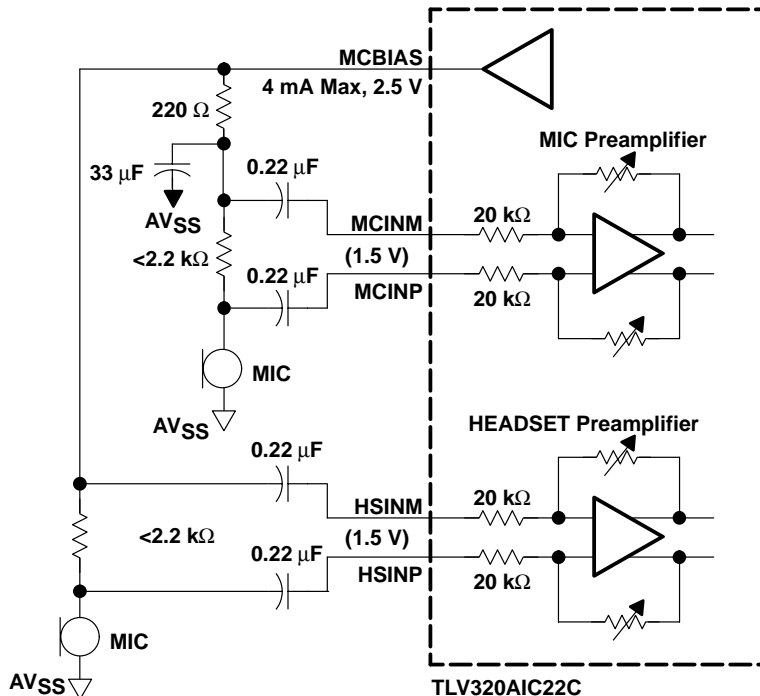

Figure 21. Microphone/Handset/Headset External Connections

caller ID interface

The caller ID amplifier interface to the telephone line is shown in Figure 22.

The value for Rx is 365 kΩ (E96 series, which has 1% tolerance). Cx is 470 pF (10% tolerance) of high-voltage rating. Voltage rating is determined based on the telecom standards of the country in which this device is used. The typical value is 1 kV. The caller ID input can be used as a lower-performance line input. For this application, a larger value capacitor is required for Cx.

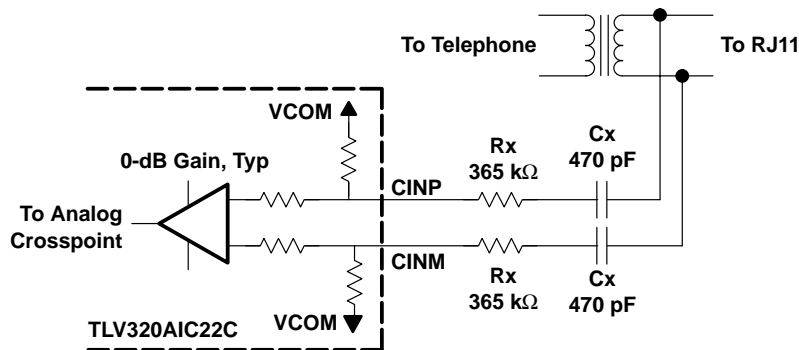
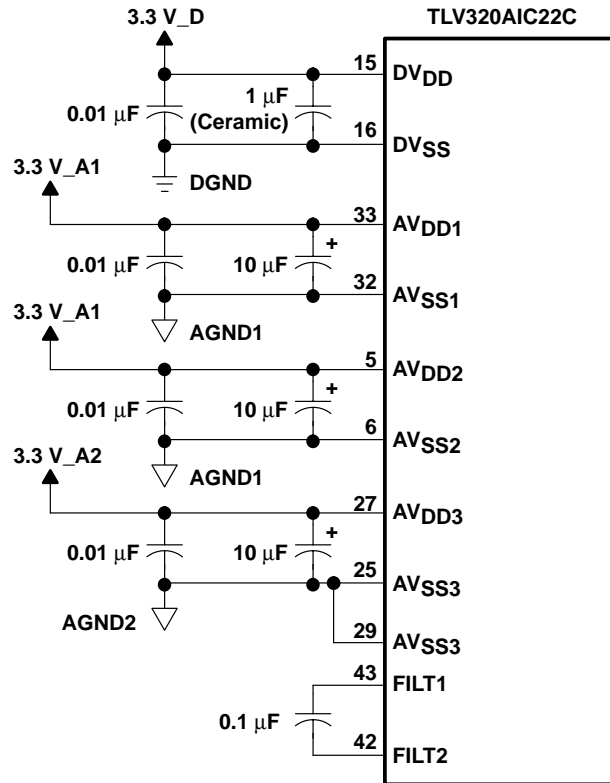

Figure 22. Typical Application Circuit for Caller ID Amplifiers

APPLICATION INFORMATION

recommended power-supply decoupling

The recommended power-supply decoupling for the TLV320AIC22C is shown in Figure 23. Both high-frequency and bulk decoupling capacitors are suggested. The high-frequency capacitors should be X7R type capacitors or better. A 1- μ F ceramic capacitor should be used to decouple the digital power supply.



3.3 V_D = 3.3-V Digital Power
DGND = Digital Ground

3.3 V_{A1} = 3.3-V Analog Power
AGND1 = Analog Ground

3.3 V_{A2} = Separate 3.3-V Analog Power
AGND2 = Separate Analog Ground

Figure 23. Recommended Decoupling

suggested configuration sequence

The default settings for the TLV320AIC22C are shown in Table 9.

Table 9. Default Codec Settings

CODEC 1 DEFAULT SETTINGS	CODEC 2 DEFAULT SETTINGS
I = 6	Same as codec 1
Analog and digital loopback not asserted	Same as codec 1
Codec power down not asserted	Same as codec 1
Software reset not asserted	Same as codec 1
ADC input PGA gain set for 0 dB	Same as codec 1
DAC output PGA gain set to 0 dB	Same as codec 1
Handset input selected for analog input	Line output selected for analog output
Handset output selected for analog output	Line input selected for analog input

TLV320AIC22C

DUAL VOICE OVER INTERNET PROTOCOL (VoIP) CODEC

SPAS041B – OCTOBER 2001 – REVISED JANUARY 2003

APPLICATION INFORMATION

suggested configuration sequence (continued)

Other default settings include:

- Handset and headset input amplifier gains are set to 14 dB.
- Microphone input amplifier gain is set to 32 dB.
- Speaker output is powered down (muted).
- FSYNC is 8 kHz, MCLK = 24.576 MHz.
- LCD DAC output voltage is 1.5 V.
- Handset output is enabled, with echo gain set to –12 dB.
- Headset output is enabled, with echo gain set to –12 dB.
- Data-valid flag is enabled in ADC data.
- Line input, output, and VCOM are enabled.
- Analog circuitry is powered up.
- Line amplifier has a filter pole at 64 kHz.
- Control information is sent every frame.
- PGA and preamp gain settings are effective after being programmed.

If the default settings are not adequate, the user can reconfigure the registers settings. An example configuration sequence after power has been applied to the TLV320AIC22C is:

1. Wait 10 μ s after the $\overline{\text{RESET}}$ has been deasserted.
2. Disable the analog outputs by programming the appropriate bits in registers 11, 13, and 14.
3. Program control register 12 for the desired MCLK and FSYNC frequencies.
4. Program control registers 1 and 7 to configure the I values.
5. Select the desired codec analog input and output paths by programming control registers 3 and 5 for codec 1 and registers 8 and 10 for codec 2. This configures the analog crosspoint.
6. Program control registers 15 (for codec 1) and 16 (for codec 2) to select the conversion mode (A-law/ μ -law/linear), the number of LSBs for the zero crossing (if enabled), and the ADC IIR filter enable/bypass.
7. Program the analog input and output gains in registers 3 and 4 for codec 1, and registers 8 and 9 for codec 2.
8. Program the handset, headset, and microphone gains (if required) in registers 11, 13, and 14.
9. Change the LCD DAC voltage (if required) by programming register 12.
10. Program how often the control information is sent via the serial interface in control register 17, if control words are not required every frame.
11. Enable the analog outputs by programming registers 11, 13, and 14.

PACKAGING INFORMATION

Orderable Device	Status (1)	Package Type	Package Drawing	Pins	Package Qty	Eco Plan (2)	Lead/Ball Finish (6)	MSL Peak Temp (3)	Op Temp (°C)	Device Marking (4/5)	Samples
TLV320AIC22CPT	ACTIVE	LQFP	PT	48	250	Green (RoHS & no Sb/Br)	NIPDAU	Level-4-260C-72HRS/ Level-3-220C-168HRS	-40 to 85	320AIC22C TLV	Samples
TLV320AIC22CPTR	ACTIVE	LQFP	PT	48	1000	Green (RoHS & no Sb/Br)	NIPDAU	Level-4-260C-72HRS/ Level-3-220C-168HRS	-40 to 85	320AIC22C TLV	Samples

(1) The marketing status values are defined as follows:

ACTIVE: Product device recommended for new designs.

LIFEBUY: TI has announced that the device will be discontinued, and a lifetime-buy period is in effect.

NRND: Not recommended for new designs. Device is in production to support existing customers, but TI does not recommend using this part in a new design.

PREVIEW: Device has been announced but is not in production. Samples may or may not be available.

OBSELETE: TI has discontinued the production of the device.

(2) **RoHS:** TI defines "RoHS" to mean semiconductor products that are compliant with the current EU RoHS requirements for all 10 RoHS substances, including the requirement that RoHS substance do not exceed 0.1% by weight in homogeneous materials. Where designed to be soldered at high temperatures, "RoHS" products are suitable for use in specified lead-free processes. TI may reference these types of products as "Pb-Free".

RoHS Exempt: TI defines "RoHS Exempt" to mean products that contain lead but are compliant with EU RoHS pursuant to a specific EU RoHS exemption.

Green: TI defines "Green" to mean the content of Chlorine (Cl) and Bromine (Br) based flame retardants meet JS709B low halogen requirements of <=1000ppm threshold. Antimony trioxide based flame retardants must also meet the <=1000ppm threshold requirement.

(3) MSL, Peak Temp. - The Moisture Sensitivity Level rating according to the JEDEC industry standard classifications, and peak solder temperature.

(4) There may be additional marking, which relates to the logo, the lot trace code information, or the environmental category on the device.

(5) Multiple Device Markings will be inside parentheses. Only one Device Marking contained in parentheses and separated by a "-" will appear on a device. If a line is indented then it is a continuation of the previous line and the two combined represent the entire Device Marking for that device.

(6) Lead/Ball Finish - Orderable Devices may have multiple material finish options. Finish options are separated by a vertical ruled line. Lead/Ball Finish values may wrap to two lines if the finish value exceeds the maximum column width.

Important Information and Disclaimer:The information provided on this page represents TI's knowledge and belief as of the date that it is provided. TI bases its knowledge and belief on information provided by third parties, and makes no representation or warranty as to the accuracy of such information. Efforts are underway to better integrate information from third parties. TI has taken and continues to take reasonable steps to provide representative and accurate information but may not have conducted destructive testing or chemical analysis on incoming materials and chemicals. TI and TI suppliers consider certain information to be proprietary, and thus CAS numbers and other limited information may not be available for release.

In no event shall TI's liability arising out of such information exceed the total purchase price of the TI part(s) at issue in this document sold by TI to Customer on an annual basis.

TAPE AND REEL INFORMATION



QUADRANT ASSIGNMENTS FOR PIN 1 ORIENTATION IN TAPE



*All dimensions are nominal

Device	Package Type	Package Drawing	Pins	SPQ	Reel Diameter (mm)	Reel Width W1 (mm)	A0 (mm)	B0 (mm)	K0 (mm)	P1 (mm)	W (mm)	Pin1 Quadrant
TLV320AIC22CPTR	LQFP	PT	48	1000	330.0	16.4	9.6	9.6	1.9	12.0	16.0	Q2

TAPE AND REEL BOX DIMENSIONS

*All dimensions are nominal

Device	Package Type	Package Drawing	Pins	SPQ	Length (mm)	Width (mm)	Height (mm)
TLV320AIC22CPTR	LQFP	PT	48	1000	367.0	367.0	38.0

IMPORTANT NOTICE AND DISCLAIMER

TI PROVIDES TECHNICAL AND RELIABILITY DATA (INCLUDING DATASHEETS), DESIGN RESOURCES (INCLUDING REFERENCE DESIGNS), APPLICATION OR OTHER DESIGN ADVICE, WEB TOOLS, SAFETY INFORMATION, AND OTHER RESOURCES "AS IS" AND WITH ALL FAULTS, AND DISCLAIMS ALL WARRANTIES, EXPRESS AND IMPLIED, INCLUDING WITHOUT LIMITATION ANY IMPLIED WARRANTIES OF MERCHANTABILITY, FITNESS FOR A PARTICULAR PURPOSE OR NON-INFRINGEMENT OF THIRD PARTY INTELLECTUAL PROPERTY RIGHTS.

These resources are intended for skilled developers designing with TI products. You are solely responsible for (1) selecting the appropriate TI products for your application, (2) designing, validating and testing your application, and (3) ensuring your application meets applicable standards, and any other safety, security, or other requirements. These resources are subject to change without notice. TI grants you permission to use these resources only for development of an application that uses the TI products described in the resource. Other reproduction and display of these resources is prohibited. No license is granted to any other TI intellectual property right or to any third party intellectual property right. TI disclaims responsibility for, and you will fully indemnify TI and its representatives against, any claims, damages, costs, losses, and liabilities arising out of your use of these resources.

TI's products are provided subject to TI's Terms of Sale (www.ti.com/legal/termsofsale.html) or other applicable terms available either on ti.com or provided in conjunction with such TI products. TI's provision of these resources does not expand or otherwise alter TI's applicable warranties or warranty disclaimers for TI products.

Mailing Address: Texas Instruments, Post Office Box 655303, Dallas, Texas 75265
Copyright © 2020, Texas Instruments Incorporated