

Single high-speed CANFD isolated transceiver module in compact DIP8 size package

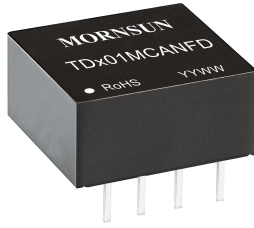

### FEATURES

- Two-port isolation test voltage(2.5kVDC)
- High baud rate of up to 5 Mbps
- Operating ambient temperature range: -40°C to +105°C
- Complies with ISO 11898-5 physical layer standard
- Bus timeout protection
- Applicable to 24V or 12V systems
- Compact size, standard DIP8 package
- EN62368 approval

TD301MCANFD / TD501MCANFD series are single-channel high-speed compact-size CANFD (flexible data rate) isolated transceiver modules with an upgraded version of CAN. The main feature of the isolated CAN transceiver is to further enhance its data transmission performance that successfully achieves a data transfer rate of up to 5Mbit/s. Its ultra-small package allows the products to be more easily embedded into the user equipment in order to achieve fully functional CAN bus network connectivity.

### Selection Guide

Certification	Part No.	Power Supply Input (VDC)	Static Current (mA)	Maximum Operating Current (mA)	Maximum Bus Voltage (VDC)	Number of Nodes
CE	TD301MCANFD	3.3	30	60	±58	110
	TD501MCANFD	5	26	60	±58	110

### Absolute Limits

Item	Operating Conditions	Min.	Typ.	Max.	Unit
Input Surge Voltage (1sec.max.)	3.3V series	-0.7	--	5	VDC
	5.0V series	-0.7	--	7	
Pin Soldering Resistance Temperature	Soldering spot is 1.5mm away from the case, 10 seconds max.	--	--	300	°C

### 3.3V series Input Specifications

Item	Symbol	Min.	Typ.	Max.	Unit	
Power Supply Input Voltage	VCC	3.15	3.3	3.45	VDC	
TXD Logic Level	High-level	V <sub>IH</sub>	2	--		3.6
	Low-level	V <sub>IL</sub>	0	--		0.8
RXD Logic Level	High-level	V <sub>OH</sub>	VCC-0.4	3.1		--
	Low-level	V <sub>OL</sub>	--	0.2	0.4	
TXD Drive Current	I <sub>r</sub>	2	--	--	mA	
RXD Output Current	I <sub>r</sub>	--	--	10		
Serial Interface	Standard CANFD controller interface for +3.3V					

### 5.0V series Input Specifications

Item	Symbol	Min.	Typ.	Max.	Unit	
Power Supply Input Voltage	VCC	4.75	5	5.25	VDC	
TXD Logic Level	High-level	V <sub>IH</sub>	2	--		5.5
	Low-level	V <sub>IL</sub>	0	--		0.8
RXD Logic Level	High-level	V <sub>OH</sub>	VCC-0.4	4.8		--
	Low-level	V <sub>OL</sub>	--	0.2	0.4	
TXD Drive Current	I <sub>r</sub>	2	--	--	mA	
RXD Output Current	I <sub>r</sub>	--	--	10		
Serial Interface	Standard CANFD controller interface for both +3.3V and +5.0V.					

## Transmission Specifications

Item	Symbol	Min.	Typ.	Max.	Unit	
Baud Rate	$f_{BIT}$	40	1000	5000	kbps	
Data Delay	TXD Transmitter Delay	$t_T$	--	55	115	ns
	RXD Receiver Delay	$t_R$	--	65	135	
	Cycle Delay	$t_{PRO(TXD-RXD)}$	--	100	250	
Dominant Timeout	$T_{to(dom)TXD}$	--	1.25	--	ms	

## Output Specifications

Item	Symbol	Min.	Typ.	Max.	Unit	
Dominant Level (Logic 0)	CANH	$V_{(OD)CANFDH}$	2.75	3.5	4.5	VDC
	CANL	$V_{(OD)CANFDL}$	0.5	1.5	2.25	
Recessive Level (Logic 1)	CANH	$V_{(OR)CANFDH}$	2	2.5	3	
	CANL	$V_{(OR)CANFDL}$	2	2.5	3	
Difference Level	Dominant Level (Logic 0)	$V_{diff(d)}$	1.5	2	3	
	Recessive Level (Logic 1)	$V_{diff(r)}$	-0.05	0	0.05	
Bus Pin Maximum Withstand Voltage	$V_X$	-58	--	+58		
Bus Transient Voltage	$V_{trt}$ , meets ISO7637-3 standard	-150	--	+100		
Bus Pin Leakage Current	( $V_{CC}=0V$ , $V_{CANFDH/L}=5V$ )	-5	--	5	uA	
Load Resistance Differential	$R_L$	--	60	--	$\Omega$	
Input Impedance Differential	$R_{diff}$	10	--	100	k $\Omega$	
CAN Bus Interface	Meets ISO/DIS 11898 standard Twisted-pair output					

## General Specifications

Item	Operating Conditions	Value
Isolation Test	Electric strength test for 1 min., leakage current <1mA	2.5kVDC
Insulation Resistance	At 500VDC	100M $\Omega$
Operating Temperature		-40 $^{\circ}$ C to +105 $^{\circ}$ C
Transportation and Storage Temperature		-50 $^{\circ}$ C to +125 $^{\circ}$ C
Operating Humidity	Non-condensing	10% - 90%
Case Temperature Rise	$T_a=25^{\circ}$ C, Free air convection	25 $^{\circ}$ C
Safety Standard		EN62368
Safety Certification		EN62368
Safety Class		CLASS III
Application Environment		The presence of dust, severe vibration, shock and corrosive gas may cause damage to the product

## Mechanical Specifications

Case Material	Black flame-retardant heat-proof plastic (UL94 V-0)
Dimensions	12.70 x 10.16 x 7.70 mm
Weight	2g(Typ.)
Cooling Method	Free air convection

## Electromagnetic Compatibility (EMC)

Immunity	ESD	IEC/EN 61000-4-2	Contact $\pm 4kV$ /Air $\pm 8kV$ (without external components, signal port)	Perf. Criteria A
	RS	IEC/EN 61000-4-3	10V/m (without external components)	Perf. Criteria A
	EFT	IEC/EN 61000-4-4	$\pm 2kV$ (without external components, signal port)	Perf. Criteria B
	Surge	IEC/EN 61000-4-5	$\pm 2kV$ (line to ground)(without external components, signal port)	Perf. Criteria A
	CS	IEC/EN 61000-4-6	3Vr.m.s (without external components)	Perf. Criteria A

### Application Precautions

1. Carefully read and follow the instructions before use; contact our technical support if you have any question;
2. Do not use the product in hazardous areas;
3. Use only DC power supply source for this product. 220V AC power supply is prohibited;
4. It is strictly forbidden to disassemble the product privately in order to avoid product failure or malfunction.
5. Hot-swap is not supported.
6. If the external input of TXD is insufficient, the pull-up resistor should be added according to the situation.

### After-sales service

1. Factory inspection and quality control are strictly enforced before shipping any product; please contact your local representative or our technical support if you experience any abnormal operation or possible failure of the module;
2. The products have a 3-year warranty period, from the date of shipment. The product will be repaired or exchanged free of charge within the warranty period for any quality problem that occurs under normal use.

### Applied circuit

Refer to the CAN Industrial Bus Interface Isolating Module Application Manual.

### Design Reference

#### 1. Typical application circuit

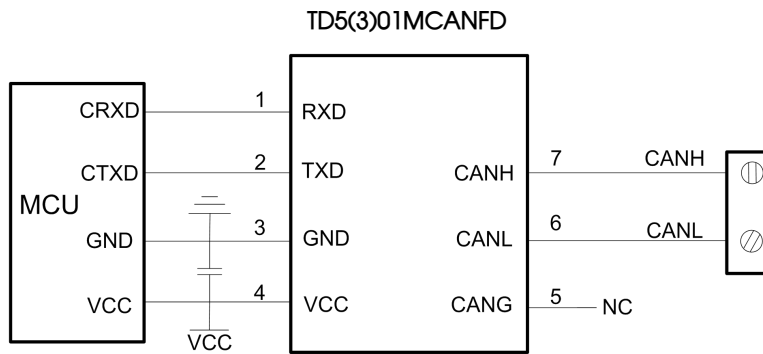

Fig. 1

#### 2. Recommended port protection circuit

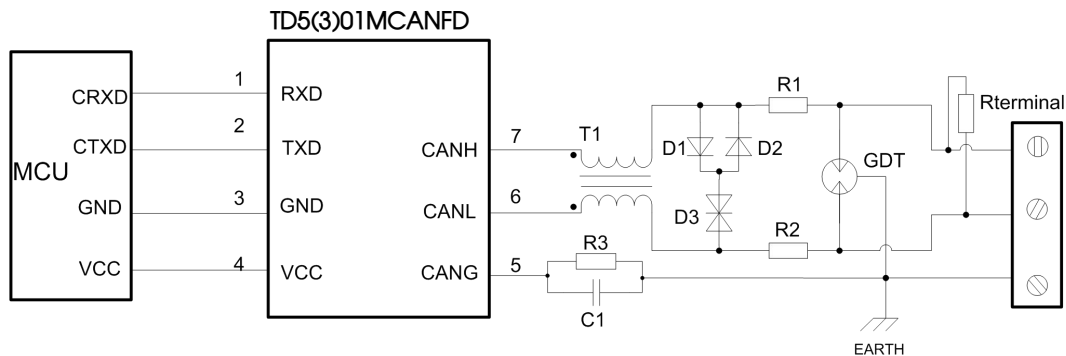

Fig. 2

Note: Ground shield of twisted wire pair reliably.  
Recommended components and values:

Component	Recommended part, value	Component	Recommended part, value
R3	1M $\Omega$ , 1206	R1, R2	2.7 $\Omega$ /2W
C1	1nF, 2kV	D1, D2	1N4007
T1	ACM2520-301-2P	D3	SMBJ30CA
GDT	B3D090L	Rterminal	120 $\Omega$

When the module is used in applications with harsh environment, it can be susceptible to large energy like lightning strike, etc. in which case, it is essential to add an adequate protection circuit to the CANFD signal ports to protect the system from failure and maintain a reliable bus communication. Figure 4 provides a recommended protection circuit design for high-energy lightning surges, with a degree of protection related to the selected protection device. Parameter description lists a set of recommended circuit parameters, which can be adjusted according to the actual application situation. Also, when using the shielded cable, the reliable single-point grounding of the shield must be achieved.

Note: The recommended components that will change the Specifications of Bus Pin Maximum Withstand Voltage by D3 and its values is a

general guideline only. It must be verified for the actual user's application. We recommended using PTC's for R1 and R2 and to use fast recovery diodes for D1 and D2.

3. For additional information, please refer to our application note on [www.mornsun-power.com](http://www.mornsun-power.com)

### Dimensions and Recommended Layout

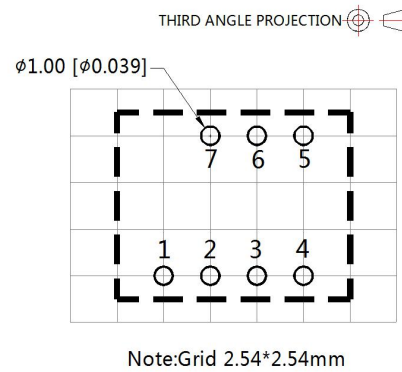
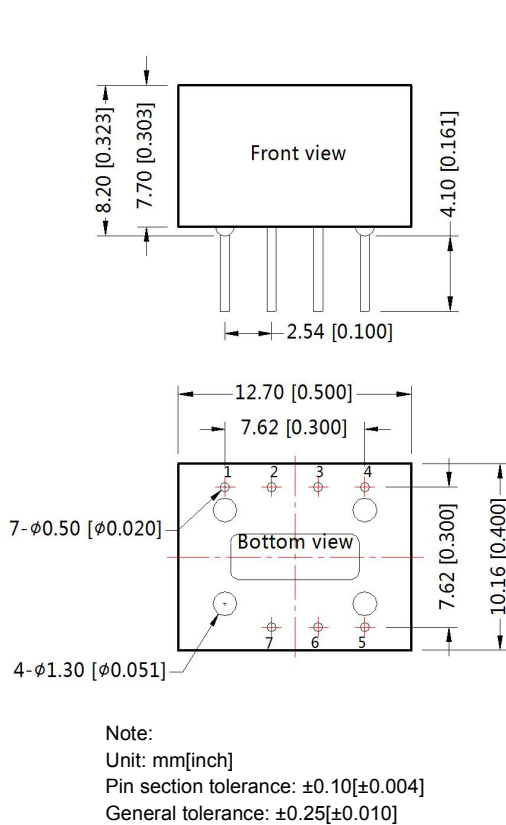

Pin-Out		
Pin	Mark	Function
1	RXD	Receiving Pin
2	TXD	Send Pin
3	GND	GND
4	VCC	Input Power+
5	CANG	Isolation Power Output CANG
6	CANL	CANL Pin
7	CANH	CANH Pin

#### Notes:

- For additional information on Product Packaging please refer to [www.mornsun-power.com](http://www.mornsun-power.com). The Packaging bag number: 58200011;
- Unless otherwise specified, parameters in this datasheet were measured under the conditions of  $T_a=25^{\circ}\text{C}$ , humidity<75%RH with nominal input voltage and rated output load;
- All index testing methods in this datasheet are based on company corporate standards;
- The above are the performance indicators of the product models listed in this datasheet. Some indicators of non-standard models will exceed the above requirements. For details, please contact our technical staff;
- We can provide product customization service, please contact our technicians directly for specific information;
- Products are related to laws and regulations: see "Features" and "EMC";
- Our products shall be classified according to ISO14001 and related environmental laws and regulations, and shall be handled by qualified units.

## MORNSUN Guangzhou Science & Technology Co., Ltd.

Address: No. 5, Kehui St. 1, Kehui Development Center, Science Ave., Guangzhou Science City, Huangpu District, Guangzhou, P. R. China

Tel: 86-20-38601850

Fax: 86-20-38601272

E-mail: [info@mornsun.cn](mailto:info@mornsun.cn)

[www.mornsun-power.com](http://www.mornsun-power.com)